

# Down to 1™

**HIGH SPEED TROUBLESHOOTING  
V22/V24 & V23 CHASSIS**

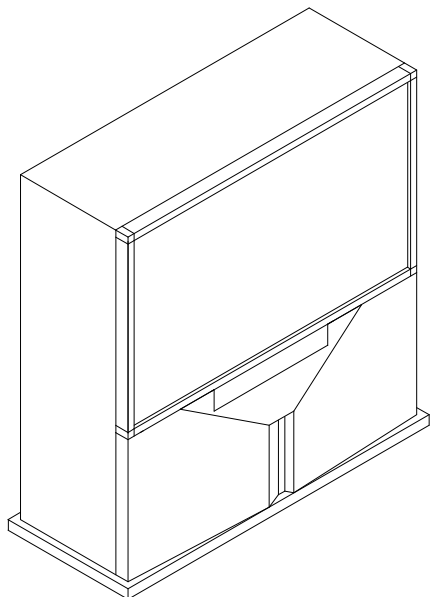

## **V22 Chassis**

WS-48313	WS-55313	WS-65313
WS-48413	WS-55413	WS-65413

## **V24 Chassis**

WS-48315	WS-55315	WS-65315
----------	----------	----------

## **V23 Chassis**

WS-48513	WS-65513	WS-73513
WS-48613	WS-65613	WS-73713
WS-55513	WS-65713	
WS-55613	WS-65813	
WS-55813		

**MITSUBISHI DIGITAL ELECTRONICS AMERICA, INC.**

9351 Jeronimo Road, Irvine, CA 92618-1904

Copyright © 2004 Mitsubishi Digital Electronics America, Inc.

All Rights Reserved



**Down To 1 - High Speed Troubleshooting**

**CONTENTS**

**INTRODUCTION ..... 2**

**SAFETY PRECAUTIONS ..... 3**

**V22/V24 - PWB FUNCTIONS AND LOCATIONS ..... 4**

**V23 - PWB FUNCTIONS AND LOCATIONS ..... 5**

**PWB PART NUMBERS ..... 6**

**TROUBLESHOOTING CHARTS**

**V22/V24 & V23 Audio ..... 7**

**V22/V24 Video/Color ..... 8**

**V23 Video/Color ..... 9**

**V22/V24 & V23 Power ..... 10**

**V22/V24 & V23 Convergence ..... 12**

## INTRODUCTION

**DOWN to 1™ Goal:** Isolate the faulty component 9 out of 10 times.

**Required tools:** Signal Generator such as Sencore VP300 or VP301

### ***DOWN to 1™ High Speed Troubleshooting***

The troubleshooting of any PTV chassis involves one of two methods. The first involves an exhaustive checking of all suspect DC and AC voltages, waveforms, and the like. This is all possible given the necessary time and equipment. The second occurs most frequently in field service, where time is often insufficient and equipment unavailable or impractical. It is then that all of a technician's practical experience must be brought to bear in order to make an educated guess as to where the product failure or difficulty may lie.

This second method is the focus of this publication and the ***DOWN to 1™*** discipline.

### ***Color, Pattern and Perception***

Observation is key to an overall evaluation strategy. The details gathered from a precise observation can go a long way toward arriving at a repair solution in a timely and efficient manner. With this understanding, MDEA has brought the combined technical expertise of its years to bear in creation of the ***DOWN to 1™*** method. For simplicity and easy memorization, color, pattern and perception are employed as the primary tools.

#### ***Color***

- Each component has its corresponding unique color.

#### ***Pattern***

- For each troubleshooting case, the component to replace is identified by an oval color pad at the terminating end of its path.

#### ***Perception***

- A perceived problem provides deductive reasoning clues to its solution.



## SAFETY PRECAUTIONS

**NOTICE:** Observe all cautions and safety related notes located inside the receiver cabinet and on the receiver chassis.

### WARNING:

1. Operation of this receiver outside the cabinet or with the cover removed presents a shock hazard from the receiver's power supplies. Work on the receiver should not be attempted by anyone who is not thoroughly familiar with the precautions necessary when working on high voltage equipment.
2. Do not install, remove or handle the picture tubes in any manner unless shatterproof goggles are worn. People not so equipped should be kept away while the picture tube is being handled. Keep the picture tube away from the body while handling.
3. When service is required, observe the original lead dress. Extra precaution should be taken to assure correct lead dress in the high voltage area. Where a short-circuit has occurred, replace those components that indicate evidence of overheating.

### X-Radiation warning

The surface of the cathode ray tubes (CRTs) may generate X-Radiation, so take proper precautions when servicing. It is recommended that a lead apron be used for shielding while handling the CRT. Use this method if possible.

When replacing the CRTs, use only the designated replacement part since it is a critical component with regard to X-Radiation. High voltage must be set as prescribed in the Service Manual under the section titled Electrical Adjustments.

### Leakage current check

Before returning the receiver to the customer, it is recommended that leakage current be measured according to the following methods.

**Cold Check** - With the AC plug removed, place a jumper across the two AC plug prongs. Connect one lead of an ohm meter to the AC plug and touch the other lead to each exposed metal part (i.e. antennas, handle bracket, metal cabinet, screw heads, metal overlay, control shafts, (etc.)), particularly any exposed metal part that has a return path to the chassis. The resistance of the exposed metal parts having a return path to the chassis **should be a minimum of 1Mega Ohm**. Any resistance below this value indicates an abnormal condition and requires corrective action.

**Hot Check...** Use the circuit shown below to perform the hot check test.

1. Keep switch S1 open and connect the receiver to the measuring circuit. Immediately after connection, and with the switching devices of the receiver in their operating positions, measure the leakage current for both positions of switch S2.
2. Close switch S1, energizing the receiver. Immediately after closing switch S1, and with the switching devices of the receiver in their operating positions, measure the leakage current for both positions of switch S2. Repeat the current measurements of items 1 and 2 after the receiver has reached thermal stabilization. **The leakage current must not exceed 0.5 milliampere (mA).**

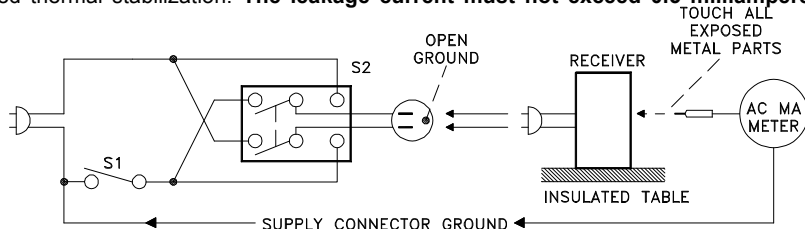

## V22/V24 Chassis - PCB Functions and Locations

PWB-Main	PWB-Power	PWB-Signal	PWB-Terminal	PWB-Doubler
Horizontal Defl.	Power Supplies	Control uPC	A/V Inputs	PIP-POP
Vertical Defl.	High Voltage	Tuning	A/V Selection	Picture Format
Audio Amp.	SVM	VCJ	3D-Y/C	3:2 Pull Down
Convergence Amps.		Convergence Generator	NTSC Video Decoders	Line Double
DBF				480i to 480p

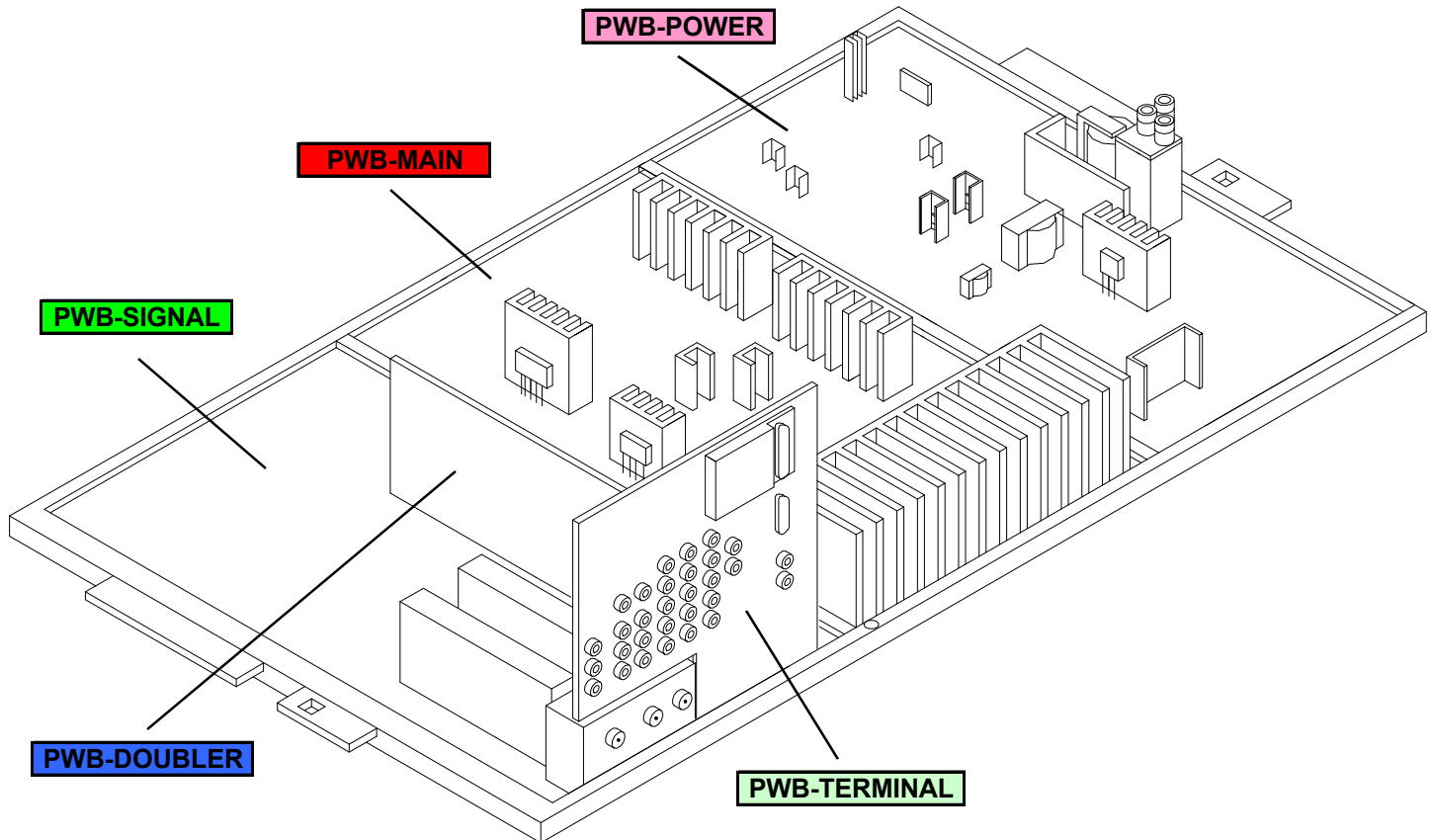

## V23 Chassis - PCB Functions and Locations

PCB-Main	PCB-Power	PCB-Signal	PCB-Terminal	PCB-Doubler	DM
Horizontal Defl.	Power Supplies	Control uPC	A/V Inputs	PIP-POP	NetCommand
Vertical Defl.	Audio Amp.	Tuning	A/V Selection	Picture Format	IEEE1394
High Voltage	Convergence Amps.	VCJ	3D-Y/C	Line Double	Card Viewer
		Convergence Generator	NTSC Video Decoders	480i to 480p	OSD-Menus
					Digital uPC Control

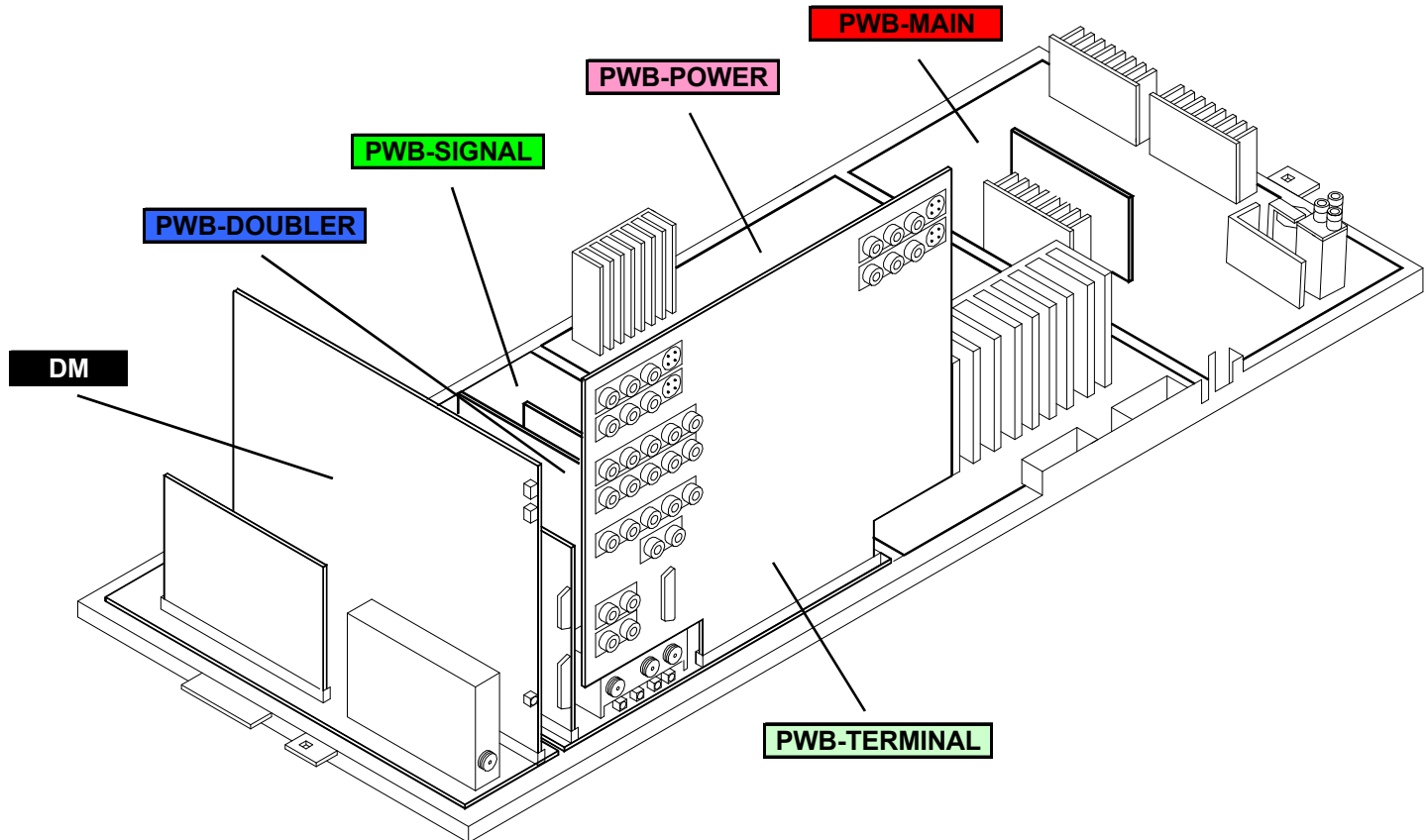

## V22/V23 Chassis - PWB Part Numbers

### PWB Part Numbers

	MODEL	PWB-MAIN	PWB-POWER	PWB-SIGNAL	PWB-TERMINAL	PWB-DOUBLER	DM
V22	WS-48313	930B899003	930B900001	930B901001-48	930B902001	934C063001	-
	WS-48413	930B899003	930B900001	930B901002-48	930B902001	934C063001	-
	WS-55313	930B899003	930B900001	930B901001-55	930B902001	934C063001	-
	WS-55413	930B899001	930B900001	930B901002-55	930B902001	934C063001	-
	WS-65313	930B899001	930B900001	930B901001-65	930B902001	934C063001	-
	WS-65413	930B899001	930B900001	930B901002-65	930B902001	934C063001	-
V24	WS-48315	930B899004	930B900002	930B901003-48	930B902001	934C063003	-
	WS-55315	930B899004	930B900002	930B901003-55	930B902001	934C063003	-
	WS-65315	930B899005	930B900002	930B901003-65	930B902001	934C063003	-
V23	WS-48513	930B903002	930B904001	930B905001-48	934C060001	934C063001	934C067001
	WS-48613	930B903002	930B904001	930B905001-48	934C060001	934C063001	934C067001
	WS-55513	930B903002	930B904001	930B905001-55	934C060001	934C063001	934C067001
	WS-55613	930B903001	930B904001	930B905001-55	934C060001	934C063001	934C067001
	WS-55813	930B903001	930B904001	930B905002-55	934C060002	934C063001	934C067002
	WS-65513	930B903001	930B904001	930B905001-65	934C060001	934C063001	934C067001
	WS-65613	930B903001	930B904001	930B905001-65	934C060001	934C063001	934C067001
	WS-65713	930B903001	930B904002	930B905002-65	934C060002	934C063001	934C067002
	WS-65813	930B903004	930B904001	930B905002-65	934C060002	934C063001	934C067002
	WS-73513	930B903004	930B904001	930B905001-73	934C060001	934C063001	934C067001
	WS-73713	930B903004	930B904002	930B905002-73	934C060002	934C063001	934C067002



# V22/V24 & V23 Chassis - Audio Problem

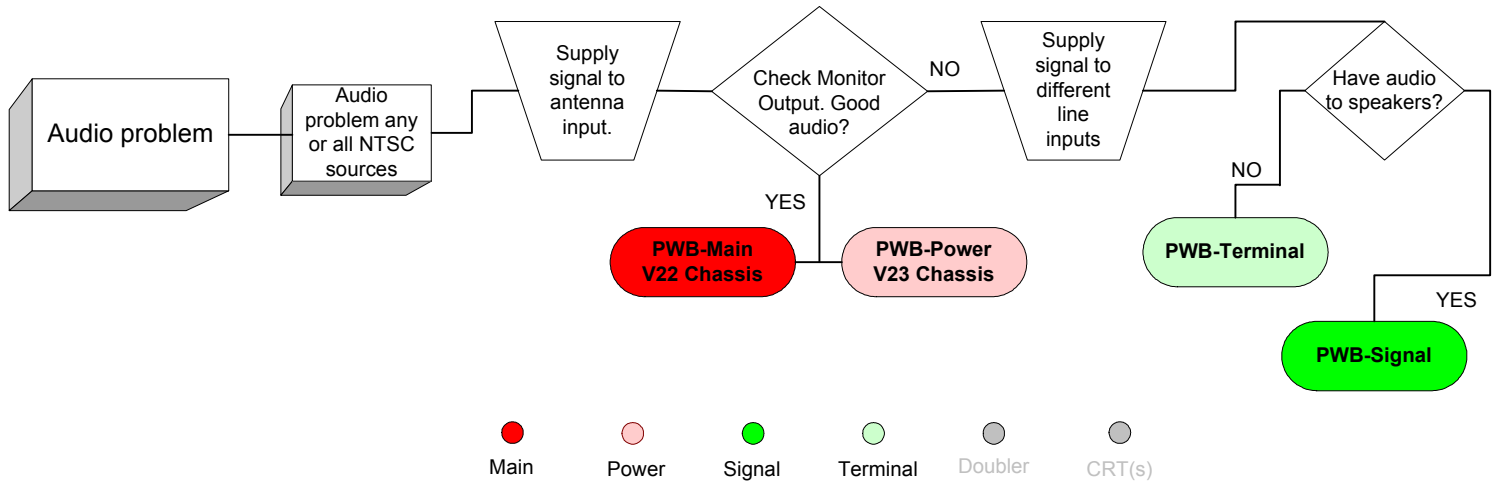

## V22/V24 Chassis - Video/Color Problem

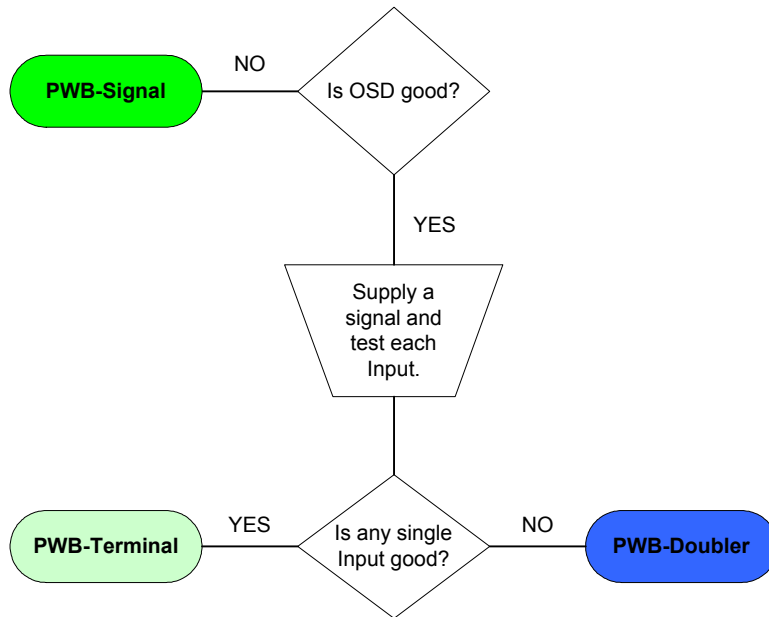

●  
Main

●  
Power

●  
Signal

●  
Terminal

●  
Doubler

●  
CRT(s)

## V23 Chassis - Video/Color Problem

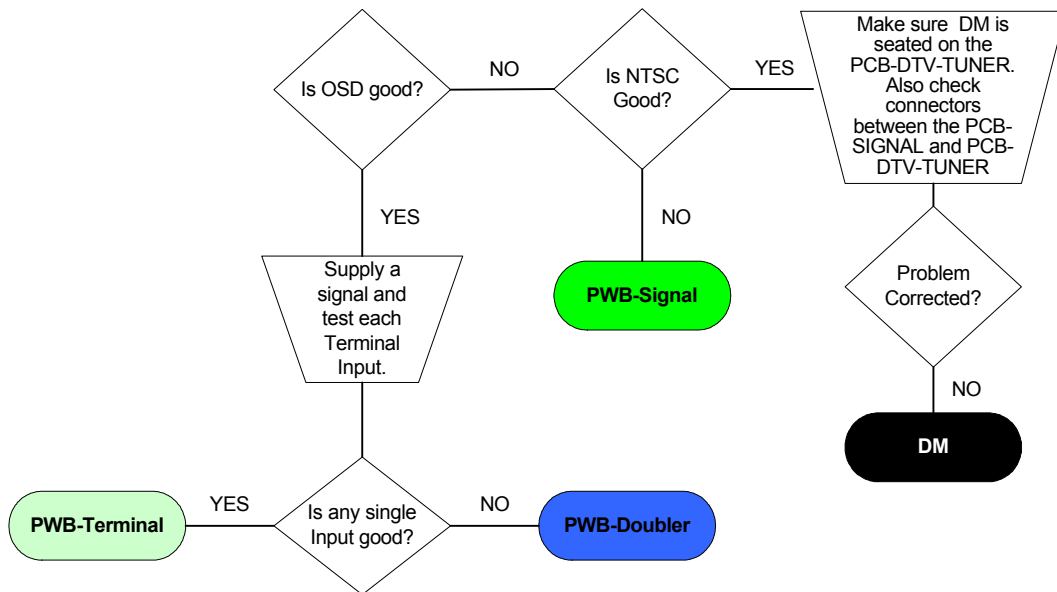

- Main
- Power
- Signal
- Terminal
- Doubler
- CRT(s)
- DM

## V22/V24 & V23 Chassis - Shut-Down Problem - (Pg 1 of 2)

### Shut-Down Problem

While the set is in Shut-Down, press and hold the Front Panel "Device" and "Menu" buttons for five seconds. Observe the flashing pattern of the front panel L.E.D. It will repeat 5 times.

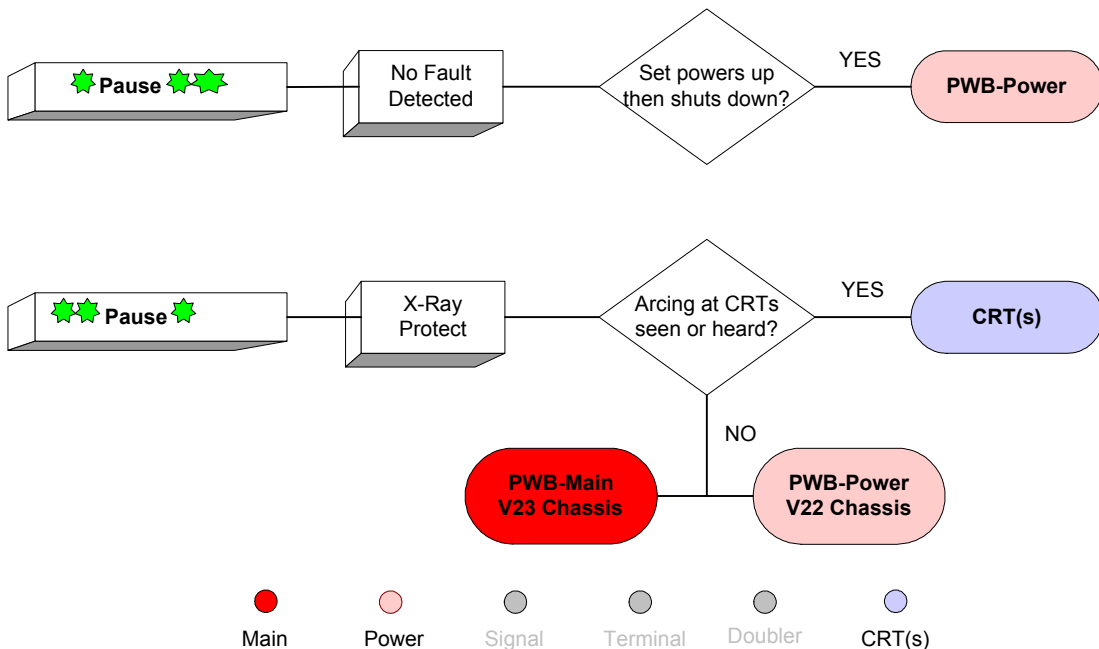

**Shut-Down Problem (Continued)**

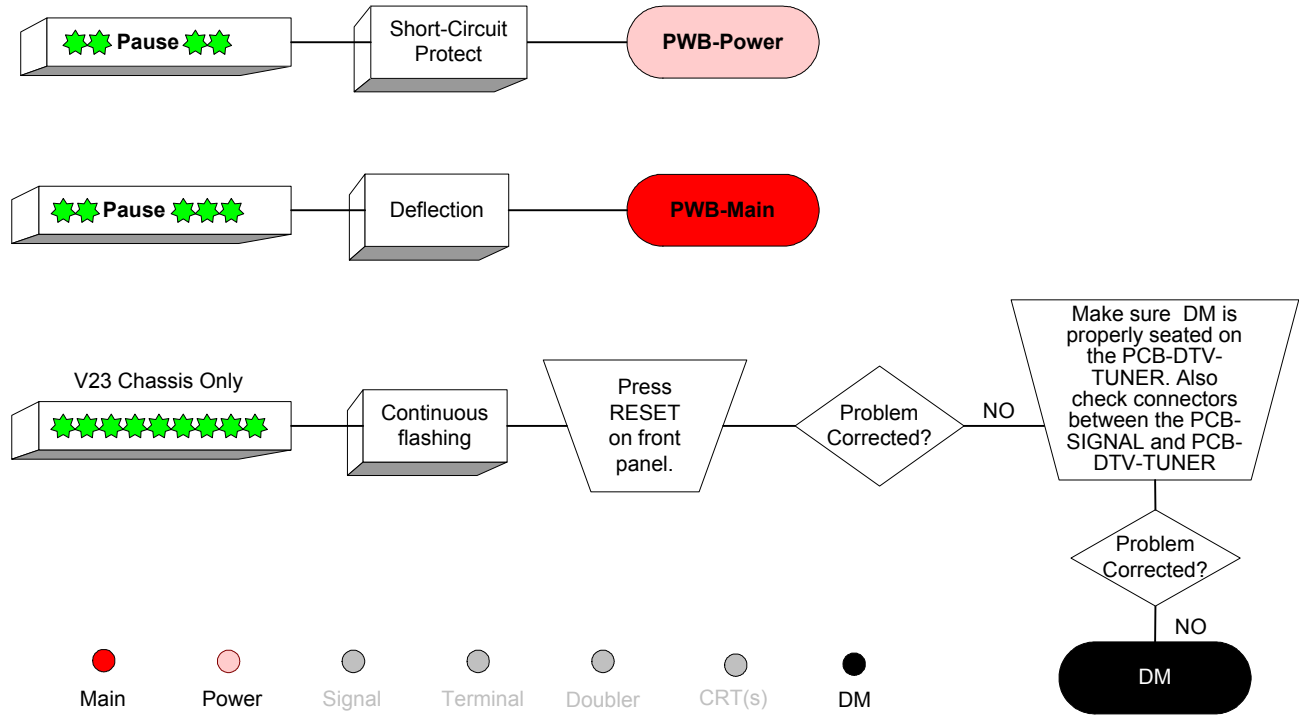

## V22/V24 & V23 Chassis - Convergence Problem

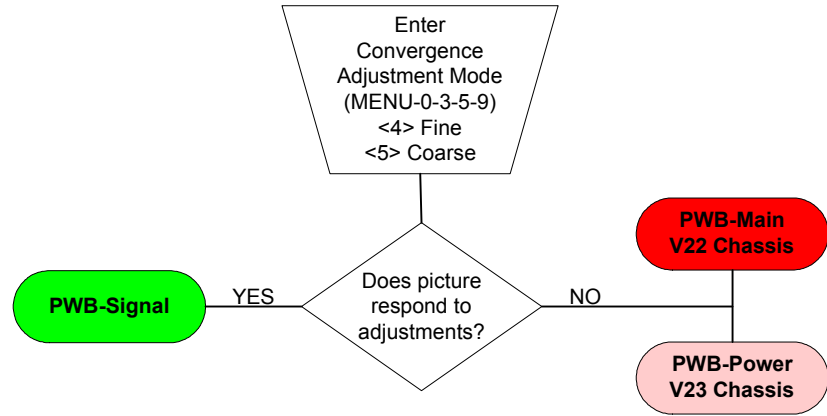

- Main
- Power
- Signal
- Terminal
- Doubler
- CRT(s)