

# Service Manual

Dishwasher  
integratable

ADG 3556 NBM

<b>Model Version</b>		<b>Page</b>
	ADG 3556 NBM 8542 556 10530	
	Technical data	2 - 4
	Spare part list	5 - 6
	Exploded view	7 - 8
	Circuit diagram	9
	Program diagram	10
	Text/Legend	11 - 16
	Family	VBL - B5

**Technical data**

**Dimension**

Height	82.0-87.0	cm
Width	59.7	cm
Depth	55.5	cm
Weight	52.7	kg

**Wooden door**

Thickness min.	16	mm
Thickness max.	20	mm
Width min.	592	mm
Width max.	595	mm
Height min.	515	mm
Height max.	600	mm
Weight max.	5.5	kg
Max. stick out over lower edge of appliance door	92	mm

**Electronic boards**

Service boards	see spare part list
Serial boards	
DUB	4619 724 06661
CB	411871
Dataset	411861

**Succession of programs**

Programs	see program diagram
Succession	1a-3b-4f-6a-7a

**Alarms**

Refill rinse aid	
Refill salt	

**Options**

Zone washing	
Delay function	

**Datas Energy Label**

Energy Performance	C
Cleaning Performance	A
Drying Performance	C
Reference program	4f

**Program information**

Start indicator	
Pre wash	
Main wash	
Drying	
End	

**Volume (normal program)**

Water	Volume	Level
Regeneration	0.3 l	15 mm
Back rinse 3x	1.0 l	68 mm
Prewash	4.8 l	122 mm
Prewash/Zone washing	4.0 l	120 mm
Main wash	4.5 l	121 mm
Main wash/Zone washing	3.5 l	117 mm
Intermediate rinse 1	4.0 l	120 mm
Intermediate rinse 1/		
Zone washing	3.5 l	117 mm
Intermediate rinse 2	4.0 l	120 mm
Intermediate rinse 2/		
Zone washing	3.5 l	117 mm
Clear rinse	4.0 l	120 mm
Clear rinse/Zone washing	3.5 l	117 mm
Safety / overflow	8.5 l	141 mm

**Measuring the level**

Remove the coarse sieve, put in a measuring meter into the sump, measure the height of the water level.

**Detergent max.**

Pre-wash	10	cm <sup>3</sup>
Main-wash	45	cm <sup>3</sup>
Rinse aid	125	cm <sup>3</sup>
6 Dosage steps	1 - 6	ml

**Water softener**

Saltcontainer	2	kg
Resin container	900	cm <sup>3</sup>
Regeneration dosage	300	cm <sup>3</sup>

**Water pressure**

Inlet pressure	0.3-10	bar
Spray pump pressure	0.4	bar

**Rotations**

Spray pump motor	2800	RPM
Drain pump motor	3000	RPM
Spray arm lower	20 - 40	RPM
Spray arm upper	25 - 35	RPM
Ceiling rotor	45 - 65	RPM

## Technical data

### Flow rates / Inlet volume

Flow meter (at 0.3 bar = quantity 1.1 l/min)	208	Imp/l
Spray pump	~ 70	l/min
Drain pump	16	l/min
Pump height max.	1.1	m
Inlet valve	4.5	l/min
Valve for Zone washing	30	l/min
Spray arm lower	33	l/min
Sprayarm upper	27	l/min
Ceiling rotor	10	l/min

### Electrical data

#### Base data

Voltage	220/230	V
Frequency	50	Hz
Total power	2.0-2.2	kW
Fuse	10	A

#### Motor

#### Spray pump motor

Voltage	220/230	V
Power consumption	160	W
HI	81	$\Omega$
HA	44	$\Omega$
Capacitor	4	$\mu$ F

#### Drain pump motor

Voltage	220/240	V
Power consumption	30	W
Resistance	146	$\Omega$

### Heating

#### 1 Element system

Voltage	220/230	V
Power consumption	1.87/2.04	kW
Resistance	24.5	$\Omega$
Heating speed	~ 2.0	$^{\circ}$ C/min
Temperature on surface	~ 115	$^{\circ}$ C
Safety thermostat self reset	85	$^{\circ}$ C

### Potentiometer

Points of measurement:	1 (black) to 2 (middle)
Position 0	0.0 k $\Omega$
Position 1	0.5 k $\Omega$
Position 2	1.0 k $\Omega$
Position 3	1.4 k $\Omega$
Position 4	1.8 k $\Omega$
Position 5	2.3 k $\Omega$
Position 6	2.6 k $\Omega$

### Water valves

#### Single valve at inlet hose

Voltage	220/240	V
Frequency	50/60	Hz
Resistance	3.76	k $\Omega$

#### Regenerating valve

Voltage	220/240	V
Frequency	50/60	Hz
Resistance	3.13	k $\Omega$

#### Valve for zone washing

Voltage	220-240	V
Frequency	50/60	Hz
Resistance	4	k $\Omega$

#### Coil of dispenser

Voltage	220/240	V
Frequency	50/60	Hz
Resistance	1.5	k $\Omega$

### Reedcontact

flow meter  
salt control  
rinse aid control

**Technical data****NTC**

20 °C	58.1	kΩ
25 °C	47.1	kΩ
30 °C	38.2	kΩ
40 °C	25.4	kΩ
50 °C	17.2	kΩ
60 °C	11.8	kΩ
70 °C	8.3	kΩ
80 °C	6	kΩ
85 °C	4	kΩ

**Regeneration**

Volume	300	cm <sup>3</sup>
Position 0 after wash cycles water hardness	10 0-5 0-0.9 0-9	°dh mmol/l °Fh
Position 1 after wash cycles water hardness	8 6-10 1-1.8 10-18	°dh mmol/l °Fh
Position 2 after wash cycles water hardness	6 11-15 1.9-2.7 19-27	°dh mmol/l °Fh
Position 3 after wash cycles water hardness	4 16-21 2.8-3.7 28.37	°dh mmol/l °Fh
Position 4 after wash cycles water hardness	3 22-28 3.8-5.0 38-50	°dh mmol/l °Fh
Position 5 after wash cycles water hardness	2 29-35 5.1-6.3 51-63	°dh mmol/l °Fh
Position 6 after wash cycles water hardness	1 36-60 6.4-10.7 64-107	°dh mmol/l °Fh
Salt consumption for regeneration	77	g
Number of cycles with 2 kg salt	26	

**Accessory**

If you need spare parts apart from the spare part list have a look in the Service Bulletin 4812 718 40084.

## Spare part list

**Model** ADG 3556 NBM  
**Service No.** 854255610530  
**Version** 854255610530

Pos. No.	12NC Code	Description
003 0	<b>4812 440 19594</b>	Traverse
004 0	<b>4812 440 18952</b>	Drip tray assy
004 1	<b>4812 401 18402</b>	Holder
011 0	<b>4812 505 18369</b>	Foot long
011 1	<b>4812 528 98004</b>	Shaft flexible
011 2	<b>4812 528 78032</b>	Slide disc f.foot
011 3	<b>4812 535 98054</b>	Gear
011 4	<b>4812 528 98001</b>	Roll f.foot
022 0	<b>4812 440 19398</b>	Side panel left
022 1	<b>4812 440 19397</b>	Side panel right
024 0	<b>4812 440 19463</b>	Panel, rear
040 1	<b>4812 417 18774</b>	Hinge left
040 2	<b>4812 417 18773</b>	Hinge right
044 0	<b>4812 492 38362</b>	Spring f.door
047 0	<b>4812 404 48591</b>	Brake f.door
047 1	<b>4812 401 18397</b>	Band,brake
047 2	<b>4812 404 68023</b>	Hook
053 0	<b>4812 440 88884</b>	Plinth
103 0	<b>4812 440 19478</b>	Door outer
105 0	<b>4812 404 48611</b>	Fastener door
105 2	<b>4812 505 68004</b>	Clip
120 0	<b>4812 440 19456</b>	Door,inner
120 1	<b>4812 440 18969</b>	Batten
130 0	<b>4812 417 58373</b>	Tilt lock cpl. bk
131 0	<b>4812 401 18416</b>	Hook lock
175 3	<b>4812 466 68572</b>	Batten
191 0	<b>4812 466 68564</b>	Gasket door
192 0	<b>4812 466 68467</b>	Gasket, door lower
241 0	<b>4812 458 18912</b>	Basket upper straight
241 1	<b>4812 458 18324</b>	Holder cups right wh
241 3	<b>4812 528 88068</b>	Wheel,basket upper (set)
241 4	<b>4812 458 18984</b>	Holder dishes
241 5	<b>4812 535 78043</b>	Bearing
241 6	<b>4812 458 18979</b>	Holder glasses
241 7	<b>4812 404 48683</b>	Hoop
241 8	<b>4812 466 68553</b>	Spacer cap set
242 0	<b>4812 458 18974</b>	Basket lower cpl.
242 1	<b>4812 528 88069</b>	Wheel,basket lower
242 4	<b>4812 466 48059</b>	Fixation
242 6	<b>4812 458 18977</b>	Support plate left
242 7	<b>4812 458 18978</b>	Support plate right
243 0	<b>4812 458 18272</b>	Basket cutlery
243 5	<b>4819 310 39859</b>	Cutlery basket KIT
243 6	<b>4812 458 18996</b>	Grille
261 0	<b>4819 462 38271</b>	Rail telescope, inner
261 1	<b>4819 404 48819</b>	Cap rail
261 2	<b>4812 462 78995</b>	Cap rail ahead
263 0	<b>4819 520 18013</b>	Ball cage cpl.
263 1	<b>4812 520 48001</b>	Ball Niro 8 D
265 0	<b>4812 404 48637</b>	Basket adjustm. cpl.
265 2	<b>4812 404 48638</b>	Grip basket adjustment
301 0	<b>4812 453 70976</b>	Control panel BK
303 1	<b>4812 460 38089</b>	Plate,handle BK
305 1	<b>4819 502 18241</b>	Screw synthetic
305 2	<b>4819 505 18191</b>	Nut

Pos. No.	12NC Code	Description
305 3	<b>4812 440 19477</b>	Batten adjustable 5mm BK
305 4	<b>4812 440 19367</b>	Batten adjustable 10mm BK
322 0	<b>4812 453 70635</b>	Insert panel BK
331 0	<b>4812 413 59018</b>	Knob program cpl. BK
332 0	<b>4812 410 28675</b>	Button BK
332 2	<b>4812 410 28672</b>	Button BK
350 1	<b>4812 440 19676</b>	Window BK
350 2	<b>4812 381 28044</b>	Lens 2-fach (WP-VBL-BI)
400 0	<b>4812 361 58126</b>	Motor + spraypump cpl.
405 0	<b>4812 360 18371</b>	Spray pump
405 1	<b>4819 515 28158</b>	Gasket
420 0	<b>4812 121 18132</b>	Capacitor
421 0	<b>4812 121 18161</b>	Interf.filter
430 0	<b>4812 360 18357</b>	Pump,draining
430 1	<b>4812 466 68506</b>	Shaft seal
450 0	<b>4812 259 28684</b>	Heating element
480 0	<b>4812 321 28394</b>	Cable harness set
480 1	<b>4812 321 28371</b>	Cable
480 3	<b>4812 401 18418</b>	Protector f.wiring
490 0	<b>4819 321 18136</b>	Cable,mains 2m SA
490 1	<b>4812 321 28367</b>	Strain relief
521 0	<b>4812 214 78365</b>	Control board (CB)
531 0	<b>4812 273 18055</b>	Switch waterhardness
531 1	<b>4812 273 18056</b>	Wheel,fingertip
571 3	<b>4812 281 28363</b>	Valve f.zone-washing
575 0	<b>4812 281 28361</b>	Regen.valve
583 0	<b>4812 271 28407</b>	Switch diaphragm
616 0	<b>4812 281 18047</b>	Contact,reed salt
616 1	<b>4812 271 58161</b>	Contact,reed rinsing agent
620 0	<b>4812 218 38091</b>	User board (DUB)
623 0	<b>4812 271 38356</b>	Microswitch
633 0	<b>4812 271 38355</b>	Microswitch door
680 0	<b>4812 418 68155</b>	Combidosage
680 1	<b>4812 466 68495</b>	Gasket
681 1	<b>4812 466 68497</b>	Gasket
681 2	<b>4812 440 18975</b>	Flap
682 0	<b>4812 466 68496</b>	Gasket
691 0	<b>4812 282 68012</b>	Feeler NTC
700 0	<b>4812 530 28804</b>	Hose, inlet aqua stop 4,2m
700 0	<b>4812 530 28848</b>	Hose, inlet aqua stop 2m
700 1	<b>4812 480 48095</b>	Sieve
700 2	<b>4812 466 68628</b>	Gasket
701 1	<b>4812 310 18153</b>	Yoke clamp set
710 0	<b>4812 418 68151</b>	Monoblock
710 2	<b>4819 310 38536</b>	Threaded ring
710 3	<b>4819 466 69562</b>	Gasket set
714 0	<b>4812 462 78993</b>	Threaded cap
714 2	<b>4812 440 18963</b>	Cabinet non-return flap
716 0	<b>4812 418 68147</b>	Reg.dosage
716 1	<b>4812 466 68475</b>	Gasket
716 2	<b>4812 462 78994</b>	Cover
721 1	<b>4812 360 68061</b>	Spray arm lower. cpl.
721 2	<b>4812 466 68491</b>	Gasket 25x2,3B
721 3	<b>4812 466 68558</b>	Gasket 30x3,0
721 4	<b>4812 440 19455</b>	Flange

## Spare part list

**Model** ADG 3556 NBM  
**Service No.** 854255610530  
**Version** 854255610530

Pos. No.	12NC Code	Description
722 0	<b>4812 360 68044</b>	Spray arm upper
722 2	<b>4812 360 68056</b>	Hub upper straight cpl.
723 0	<b>4812 360 68049</b>	Spray arm ceiling
723 1	<b>4819 310 39831</b>	Kit
726 0	<b>4812 530 28786</b>	Tube
726 1	<b>4812 530 28787</b>	Tube
726 2	<b>4812 505 18358</b>	Nut
726 3	<b>4812 466 68512</b>	Gasket
726 4	<b>4812 462 79633</b>	Centering
743 0	<b>4812 511 48171</b>	Capacitor
743 1	<b>4812 530 28102</b>	Hose, inlet
743 3	<b>4812 505 18364</b>	Nut
743 4	<b>4812 530 28807</b>	Hose 9x1,5x270+10
743 7	<b>4812 466 68514</b>	Gasket
751 0	<b>4812 418 18205</b>	Water collector
751 1	<b>4819 310 39826</b>	Water guide service kit
755 0	<b>4812 530 28849</b>	Bend
755 2	<b>4812 530 48148</b>	Tray,leak
756 0	<b>4812 360 58099</b>	Floater
761 0	<b>4812 480 58082</b>	Sieve fine
761 2	<b>4812 418 18204</b>	Cover sieve
762 0	<b>4812 480 58084</b>	Microfilter
763 0	<b>4812 480 58083</b>	Sieve coarse
781 0	<b>4812 530 28737</b>	Hose,draining
781 1	<b>4819 530 28286</b>	Sleeve hose
781 2	<b>4819 492 68405</b>	Clip f.non-return valve
781 3	<b>4812 281 28364</b>	Flap non-return
783 1	<b>4812 530 28806</b>	Hose connection
783 5	<b>4812 530 28851</b>	Distributor
783 6	<b>4812 530 28796</b>	Hose 10x3x180+10
791 0	<b>4812 532 68067</b>	Gasket
791 2	<b>4812 530 58093</b>	Gasket
791 4	<b>4812 466 68503</b>	Gasket
791 5	<b>4812 466 68504</b>	Gasket
794 1	<b>4819 530 58032</b>	Gasket 20x2,5
901 0	<b>4822 401 10492</b>	Clamp,hose 14-24 mm
901 1	<b>4812 401 18424</b>	Strap 050,0
901 2	<b>4812 401 18157</b>	Strap 32-50/9 C61
901 5	<b>4812 401 48573</b>	Strap 028,6
901 7	<b>4812 401 18427</b>	Strap 031,6
901 8	<b>4812 401 18075</b>	Strap 20-32/9 mm
902 1	<b>4812 466 78015</b>	Fastener f.buildt-in models
902 2	<b>4812 404 78241</b>	Holder
904 2	<b>4812 462 79657</b>	Cover BK 3,5x5
910 1	<b>4812 502 18394</b>	Screw 3,5x14-H
910 2	<b>4812 502 18363</b>	Screw 4,0x12-H
910 3	<b>4812 502 18389</b>	Screw NIRO A2
910 4	<b>4812 502 18385</b>	Screw M3,5x8-T15M
910 5	<b>4812 502 18393</b>	Screw 3,5x9-1 Tx15
910 7	<b>4812 502 18397</b>	Screw INOX A2 M 5X12
910 9	<b>4812 401 18425</b>	Screw 2,5x18-H
964 1	<b>4812 466 68573</b>	Gasket housing upper
993 1	<b>4812 466 78388</b>	Foil protection
993 2	<b>4812 404 48609</b>	Socket wrenc foot
993 5	<b>4822 532 80216</b>	Funnel salt

Pos. No.	12NC Code	Description
993 6	<b>4812 466 78386</b>	Foil protection add.



**Exploded view**

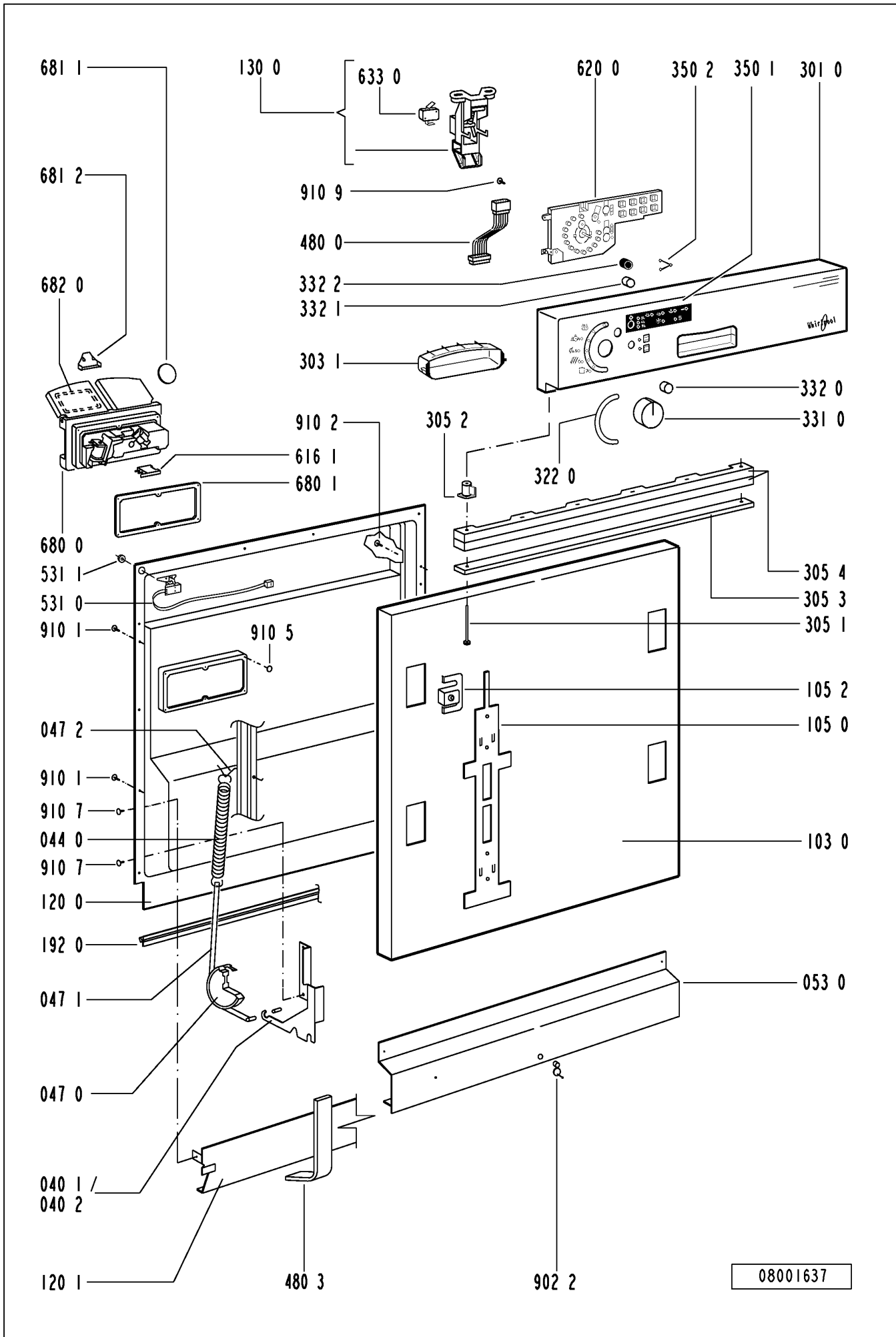

08001637



## Circuit diagram

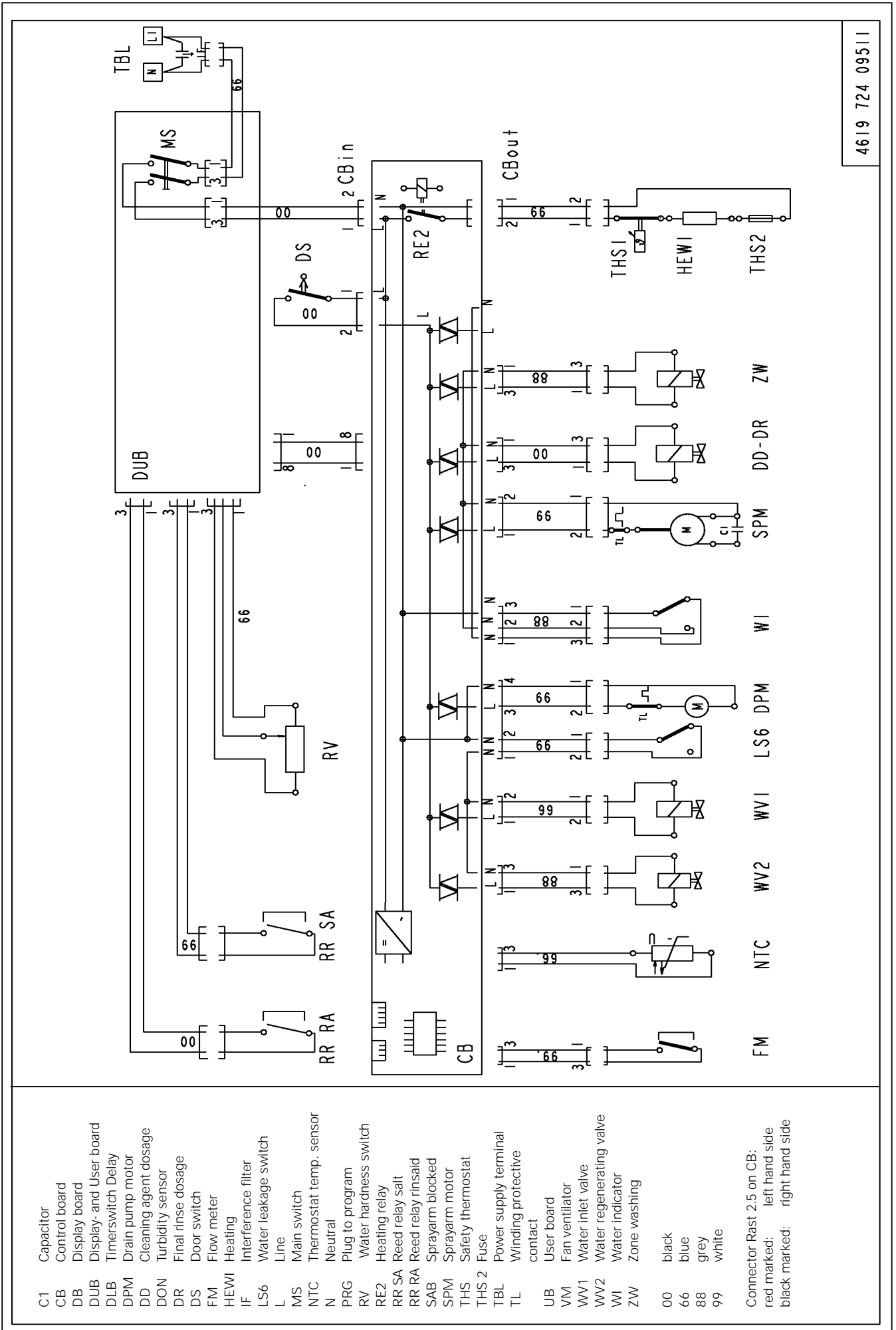

4619 724 09511

- C1 Capacitor
  - CB Control board
  - DB Display board
  - DUB Display- and User board
  - DLB Timerswitch Delay
  - DPM Drain pump motor
  - DON Cleaning agent dosage
  - DR Turbidity sensor
  - DR Final rinse dosage
  - DS Door switch
  - FM Flow meter
  - HEWI Heating
  - IF Interference filter
  - LS6 Water leakage switch
  - L Line
  - MS Main switch
  - NTC Thermostat temp. sensor
  - N Neutral
  - PRG Plug to program
  - RV Water hardness switch
  - RE2 Heating relay
  - RR SA Reed relay salt
  - RR RA Reed relay rinsaid
  - SAB Sprayarm blocked
  - SPM Sprayarm motor
  - THS Safety thermostat
  - THS 2 Fuse
  - TBL Power supply terminal
  - TL Winding protective contact
  - UB User board
  - VM Fan ventilator
  - WV1 Water inlet valve
  - WV2 Water regenerating valve
  - WI Water indicator
  - ZW Zone washing
  - 00 black
  - 66 blue
  - 88 grey
  - 99 white
- Connector Rast 2.5 on CB:  
 red marked: left hand side  
 black marked: right hand side



## Text/Legend

**Test procedure for SERVICE-TEST-PROGRAM DOLPHIN dishwashers  
Whirlpool VBL without 2 digit 7 segment-display**

Switch on the appliance. If there is no failure indicated, than:

1. Start the passive test program.  
If there is a defective component indicated, open the plinth and take out the control board (CB).
2. Check the component.  
Unplug the indicated component from the control board (CB) and check it by using an Ohm-measure equipment.  
If the ohms are not correct, check the cables to the component and check the component itself.
3. Check the control board (CB).
4. At the end of the repair start the appliance and delete the failure. After this, start the passive and active test program again to see that the failure is solved.

More details: s. following pages.

**Attention:**

First unplug the appliance, then set the connection clamps of the volt measurement on the test points.

Danger for short circuit. Short circuits on components can damage the control board (CB).

If electronic boards are wet, do not switch the appliance on.

For check the appliance, plug in the appliance.

Failures, which occurred during the program will store and indicate by flashing start LED.

Then start the test program without erase the failure before. The failure will indicate.

To erase the failures, you must push the start button longer than 3 seconds.

The failures

- F1 NTC break
- F2 water leakage
- F9 continuous water inlet

are checked and indicated immediately after start of the program.

Therefore these failures have to be solved before starting the active test program.

When these failures are not solved, the active test program does not run.

The electrical components get their voltage via triac from the control board (CB). For testing the volume of voltage the volt meter must be parallel to the component (the component must be connected). If the component is disconnected, then the outcomed voltage from the control board (CB) is reduced.

**After starting a program this program is locked. That means neither by unplugging/switching of the appliance nor by setting an other program, the first setted program can be changed. Changing of the program is only possible by pushing the start button again for longer than 3 sec..**

**Attention: On new service control boards the first service test program is without back rinsing. Dangerous for overfilling the appliance, in case the appliance is not empty. By running the test program a second time the back rinsing will be carried out as usual.**

## Text/Legend

### Handling of failures

- F0 Sensor failure  
Will not indicate for the customer. The programs will finish even there is a failure. The Failure is indicated only in the active test program after 10 – 30 second's. The active test program will finish as well, even there is a failure.  
If the failure in a sensor program appear, the machine will always choose the highest consumption (best cleaning result).  
- None or wrong output from the sensor  
- Unlogical or unreal measurement results  
Reason:  
- Defective electronic of the sensor  
- Optoelectrical parts in the sensor defect  
- Case of the sensor is very dirty  
- Connection between sensor and control board (CB) interrupted  
Attention: The failure code will not store.
- F1. NTC break  
Temperature out of the normal value (-3°C till +85°C)  
- temperature inside higher than +85°C  
- NTC defective  
- dishwasher is frozen, less than -3°C  
Fill in the appliance a cup of warm water to warm it up before you start it, if the temperature is less than -3°C
- F2. water leakage  
- water is in the drip tray  
float (LS6) switches off the WV1 and the electronic switches on the DPM till WI reports empty
- F3. heating system defective  
Indicated after app. 25 minutes (1. check after 5 min., after that follow 2 more checks, before the failure is indicate)  
- too less heating speed (lower 1,5 °C in 10 min.)  
- heating (HEW) defective  
- relays (RE2) on control board (CB) is defective  
- NTC - resistance fluctuation  
- water indicator (WI) defective (is switched off) - spray pump (SPM) is not working
- F4. draining failure  
drain pump starts and after 4 min. the WI detects not empty  
- drain pump (DPM) defective  
- siphon closed  
- control board (CB) defective  
- water indicator (WI) defective (is switched on)
- F6. water tap closed (only indicated after start of the active test program)  
water valve (WV1) is switched on but flow meter (FM) sends no impulses (less than 10 imp. in 10 sec.) and the water indicator (WI) is off (empty)  
- water tap closed  
- water inlet hose blocked  
- water inlet valve (WV1) defective  
- flow meter (FM) defective (leads to FM failure)















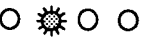

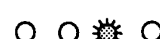
## Text/Legend

- F7. flow meter failure  
water inlet valve (WV1) is switched on and the water indicator (WI) is on (full).  
- flow meter (FM) sends to less impulses (less than 10 imp. in 10 sec.)  
- water tap closed  
- water inlet hose blocked  
- water inlet valve (WV1) defective  
- flow meter (FM) defective
- F8. water level failure  
failure monitored during spray pump is on and the water indicator switches back more than 20 times in 2 min.  
- water indicator defective (should switch on after app. 1 litre)  
- sieve blocked  
- water strongly foams  
- pot has turned off and is filled with spray water  
- no stable spray pump (SPM) working
- F9. continuous water inlet  
water inlet valve (WV1) is switched off, water indicator (WI) on, flow meter (FM) sends impulses (more than 10 imp. in 10 sec.)  
- water inlet valve (WV1) mechanically not closed  
- triac (CB) permanently switched on. (short circuit)
- reaction: interval 30 sec. draining / 20 sec. tracing

For salt, rinse aid, zone wash valve, sieve valve failure see active test program.

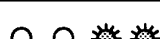
**Text/Legend**

**FAILURECODES for Whirlpool VBL without 2 digit 7 segment display**

Alarm / Failures	Failurecode, which is indicated for the customer on the Start-LED and the Programsequence, directly after it's occurred	
	Both indications parallel on appliances with Programsequence	
	Indication on appliances without Programsequence	
<b>F0 Sensore failure</b>	<b>Indicated only in the active testprogram</b>  START   10 x flashing 1s break 10 x flashing.....	 PS1 PS2 PS3 PS4
<b>F1 NTC-break</b>	START   1 x flashing 1s break 1 x flashing.....	 PS1 PS2 PS3 PS4
<b>F2 Water leakage</b>	START   2 x flashing 1s break 2 x flashing.....	 PS1 PS2 PS3 PS4
<b>F3 Heating system defective</b>	START   3 x flashing 1s break 3 x flashing.....	 PS1 PS2 PS3 PS4
<b>F4 Draining failure</b>	START   4 x flashing 1s break 4 x flashing.....	 PS1 PS2 PS3 PS4
<b>F6 Water tap closed</b>	START   6 x flashing 1s break 6 x flashing.....	 PS1 PS2 PS3 PS4
<b>F7 Flow meter failure</b>	START   7 x flashing 1s break 7 x flashing.....	 PS1 PS2 PS3 PS4
<b>F8 Waterlevel failure</b>	START   8 x flashing 1s break 8 x flashing.....	 PS1 PS2 PS3 PS4
<b>F9 Continous waterinlet</b>	START   9 x flashing 1s break 9 x flashing.....	 PS1 PS2 PS3 PS4

 LED flashing  
 LED off

**PS 1 till PS 4: Programsequence**

- The failurecode "Sprayarm blocked (F5)" is not present on the Whirlpool VBL Version
- On the 1 digit 7 segment-display the failure will shown with a "F" in the display and a flashing Start-LED.
- The failure F0 (Sensor failure) will only indicated in the active testprogram, that means, this failure is not visible for the customer.

## Text/Legend

VBL

5

4619 724 14971-1

With the passive test program, you can check all LED's and buttons. If there is no failure the passive test program runs normal.

**Attention:**

If you can't start the active test program (Start button don't flash), normally there is one of the following failures detected: F1, F2 or F9

When these failures are not solved before, the passive and active test program will not run. After solving the failure you must "sign" (erase) the failure.

A present failure will be indicate directly after you switch on the appliance

### Start procedure

Start the passive test program if there is no failure indicated

If there is no failure the passive test program runs normal.

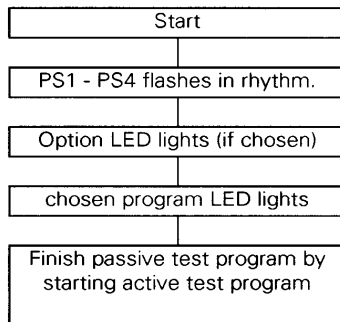

1. Switch off the appliance.
2. Push start button and hold it.
3. Choose programplace 1 (turn to the left side).
4. Finish pushing the start button when the start LED flashes.
5. Test all LEDs by operate the buttons and the programknob. After the check, turn the programknob on programplace 1
6. Start the active testprogram by pushing the start button again
7. Failure indication.
8. Repair the failure
9. Solve the failure by pushing the start button for longer than 3 sec.
10. Start the active testprogram again, to see, if the failure is really solved

### **Active test program starts (see next page)**

#### Program sequence LED

PS1	1. LED	prewash	
PS2	2. LED	mainwash intermediate rinse final rinse	
PS3	3. LED	drying (regeneration)	
PS4	4. LED	end	goes off if any button is pushed
			goes off after 30 min progr. is finished

**Text/Legend**

**Active test program**

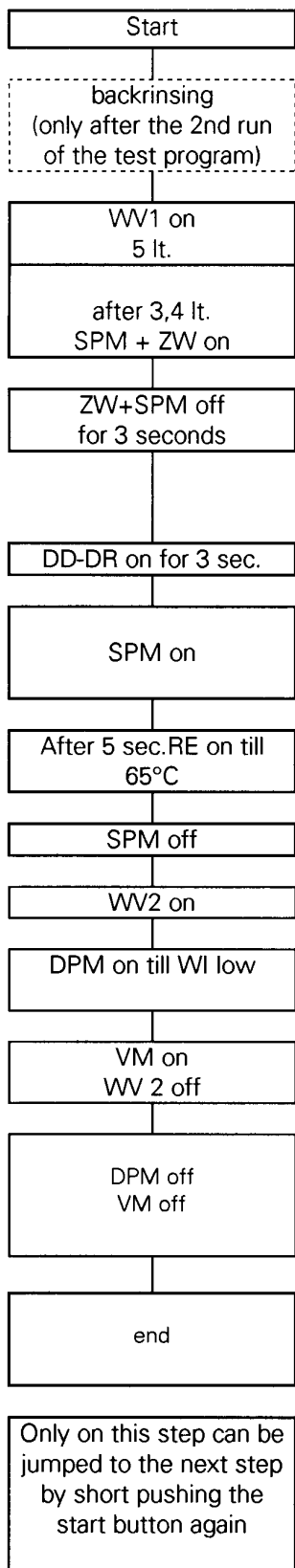

PS4  
on

Remarks

The active test program runs to the failure position and stops or, if there is no failure, it runs to the end.

To leave the test program push the start button for longer than 3 second's.

Too less salt or too less rinse aid leads not to the stop of the appliance.

The function of the zone wash valve can only be checked optically.  
 A defect leads to a not stable SPM pressure.

When the failure position is reached, the failure indication is like on the page "Failurecodes"

**Attention:**

If you can't start the active test program (Start button don't flash), normally there is one of the following failures detected: F1, F2 or F9

When these failures are not solved before, the active test program will not run. After solving the failure you must "sign" (erase) the failure.

Remarks:

**ZW on:** zone wash valve on = no water on the upper sprayarm.

**ZW off:** zone wash valve off = water on the upper sprayarm.