

---

# Service Manual

## Dishwasher

### ADP 4520 WH

---

<b>Model Version</b>		<b>Page</b>
	ADP 4520 WH 8511 763 10810	
	Technical data	2 - 4
	Spare part list	5 - 6
	Exploded view	7 - 8
	Circuit diagram	9
	Program diagram	10
	Text/Legend	11 - 16
	Family	WRC - EBL LOW 5

**Technical data**

**Dimension of Free standing appliances with flat/ square outer door**

Height	85.0	cm
Width	59.7	cm
Depth	59.6	cm
Weight	56	kg

**Electronic boards**

Service boards	see spare part list
Serial boards	see on the boards itself
Programmed control board and programming of version , see „Board Service“ and „DATA“ on rating plate of inner door:	
UCB	704742
Data set	704732

Basic UCB, not programmed  
 see on the board itself 4619 727 04651

**Succession of programs**

Programs	see program diagram
Succession	P1a-P3a-P5c-P6a-P7a

**Datas Energy Label**

Reference program	P5c
Energy Performance	A
Cleaning Performance	A
Drying Performance	B

**Alarms**

- Refill rinse aid
- Refill salt

**Program information**

Start indicator

All programs will be locked after start. Changing the program or finishing the program will be possible only after pressing the start button for longer then 1.5 sec. (Break by customer)

A switching off the appliance or unplug the appliance for a while, this will frozen the program step and later on, the program continuos on the same position.

Exception: Switching off the appliance or unplug the appliance during the drying phase, this will lead directly to the end of the program.

**Water Volume at permanent spray system**

Water	Volume	Level
Regeneration	0.3 l	15 mm
Back rinse 3x	1.0 l	60 mm
Prewash	4.8 l	120 mm
Main wash	4.2 l	118 mm
Intermediate rinse 1	4.2 l	118 mm
Intermediate rinse 2	4.2 l	118 mm
Clear rinse	4.2 l	118 mm
Safety/ overflow	8.5 l	141 mm

**Measuring the level**

Remove the coarse sieve, put in a measuring meter into the sump, measure the height of the water level.

**Detergent max.**

Pre-wash	10	cm <sup>3</sup>
Main-wash	40	cm <sup>3</sup>
Rinse aid	135	cm <sup>3</sup>
6 Dosage steps	1 - 6	ml

**Water softener**

Saltcontainer	2	kg
Resin container	700	cm <sup>3</sup>
Regeneration dosage	300	cm <sup>3</sup>

**Water pressure**

Inlet pressure	0.3 - 10	bar
Spray pump pressure	0.3	bar

**Rotations**

Spray pump motor	2800	RPM
Drain pump motor	3000	RPM
Spray arm lower	30 - 40	RPM
Spray arm upper	30 - 40	RPM

## Technical data

### Flow rates/ Inlet volume

Flow meter (at 0.3 bar = quantity 1.1 l/min)	208	Imp/l
Spray pump	65	l/min
Drain pump	16	l/min
Pump height max.	1.1	m
Inlet valve	4	l/min
Spray arm lower	~ 33	l/min
Sprayarm upper	~ 27	l/min
Sprayarm/ Shower top	~ 8	l/min

### Electrical base data

Voltage	220/ 230	V
Frequency	50	Hz
Total power	2.0 - 2.2	kW
Fuse	10	A

### Spray pump motor permanent spray system

Voltage	220/ 240	V
Power consumption	80	W
Frequency	50	Hz
Resistance	30	$\Omega$

### Drain pump motor

Voltage	220/ 240	V
Power consumption	30	W
Resistance	146	$\Omega$

### Heating - 1 Element system

Voltage	220/ 230	V
Power consumption	1.87/ 2.04	kW
Resistance	24.5	$\Omega$
Heating speed	~ 2.0	$^{\circ}\text{C}/\text{min}$
Temperature on surface	~ 115	$^{\circ}\text{C}$
Safety thermostat self reset		
(Temperature of water)	~ 85	$^{\circ}\text{C}$
Fuse	206	$^{\circ}\text{C}$

### Water safty options

Waterstop system	Aquasafe
------------------	----------

### Single electric water inlet valve

Voltage	220/ 240	V
Frequency	50/ 60	Hz
Resistance	3.76	$\text{k}\Omega$

### Regenerating valve

Voltage	220/ 240	V
Frequency	50/ 60	Hz
Resistance	3.13	$\text{k}\Omega$

### Coil of dispenser

Voltage	220/ 240	V
Frequency	50/ 60	Hz
Resistance	1.3	$\text{k}\Omega$

### Reed contacts

flow meter  
salt control  
rinse aid control

### NTC

20 $^{\circ}\text{C}$	58.1	$\text{k}\Omega$
25 $^{\circ}\text{C}$	47.1	$\text{k}\Omega$
30 $^{\circ}\text{C}$	38.2	$\text{k}\Omega$
40 $^{\circ}\text{C}$	25.4	$\text{k}\Omega$
50 $^{\circ}\text{C}$	17.2	$\text{k}\Omega$
60 $^{\circ}\text{C}$	11.8	$\text{k}\Omega$
70 $^{\circ}\text{C}$	8.3	$\text{k}\Omega$
80 $^{\circ}\text{C}$	6	$\text{k}\Omega$
85 $^{\circ}\text{C}$	4	$\text{k}\Omega$

### Regeneration

Volume	300	$\text{cm}^3$
after wash cycles	depending on the water softener setting	
water hardness	0 - 40	$^{\circ}\text{dh}$
	0 - 10.7	$\text{mmol/l}$
	0 - 107	$^{\circ}\text{Fh}$
Salt consumption for regeneration	~ 77	g
Number of cycles with 2 kg salt	~ 26	

## Technical data

### Water softener setting

To change the water softener setting:

- Push the POWER button on
- Change to program 2
- Hold the START button for 5 seconds until the LED is flashing
- Water softener setting is shown by flashing LED
- By pushing the START button you can change the setting
- Push the POWER button off to save and exit the water softener setting

Water hardness	German degrees °dH	French degrees °fH	English degrees Clarke °e	mmol/l	Water softener setting is shown by flashing LED
1 soft	0 - 5	0 - 9	0 - 6,3	0 - 0.9	1 x
1 - 2 soft/ medium	6 - 10	10 - 18	7 - 12.6	1 - 1.8	2 x
2 medium	11 - 15	19 - 27	13.3 - 18.9	1.9 - 2.7	3 x
3 medium/ hard	16 - 21	28 - 37	19.6 - 25.9	2.8 - 3.7	4 x
4 hard	22 - 28	38 - 50	26.6 - 35	3.8 - 5.0	5 x
4 very hard	29 - 35	51 - 63	35.7 - 44.1	5.1 - 6.3	6 x
4 extremely hard	36 - 60	64 - 107	44.8 - 74.9	6.4 - 10.7	7 x

### Accessory

If you need spare parts apart from the spare part list have a look in the Service Bulletin 4812 718 40084.

## Spare part list

Model **ADP 4520 WH**  
Service No. **851176310810**  
Version **851176310810**

Pos. No.	12NC Code	Description
003 0	<b>4812 440 19594</b>	Traverse
004 0	<b>4812 440 18952</b>	Drip tray assy
004 1	<b>4812 401 18402</b>	Holder
011 0	<b>4812 505 18357</b>	Foot short
022 0	<b>4812 440 10755</b>	Side panel left
022 1	<b>4812 440 10754</b>	Side panel right
024 0	<b>4812 440 10417</b>	Panel, rear
024 5	<b>4812 440 10944</b>	Damper fix Motor synch
030 0	<b>4812 310 18916</b>	Table top cpl. WH
034 0	<b>4812 404 78237</b>	Spacer
034 1	<b>4812 404 78242</b>	Fastener table top
040 1	<b>4812 417 18774</b>	Hinge left
040 2	<b>4812 417 18773</b>	Hinge right
040 3	<b>4812 417 18923</b>	Protector f.door (set)
044 0	<b>4812 492 38358</b>	Spring f.door
047 0	<b>4812 404 48746</b>	Brake f.door
047 1	<b>4812 401 18397</b>	Band,brake
047 2	<b>4812 404 68023</b>	Hook
053 0	<b>4812 440 89031</b>	Plinth WH
053 4	<b>4812 440 89036</b>	Plinth rounded WH
065 0	<b>4812 466 48052</b>	Insulation
103 0	<b>4812 440 10758</b>	Door outer
120 0	<b>4812 440 19456</b>	Door,inner
120 1	<b>4812 440 18969</b>	Batten
130 0	<b>4812 417 58373</b>	Tilt lock cpl. bk
131 0	<b>4812 401 18416</b>	Hook lock
191 0	<b>4812 466 68564</b>	Gasket door
191 3	<b>4812 466 68533</b>	Gasket
192 0	<b>4812 466 68467</b>	Gasket, door lower
241 0	<b>4812 458 19027</b>	Basket upper straight
241 1	<b>4812 458 18324</b>	Holder cups right wh
241 3	<b>4812 528 88068</b>	Wheel,basket upper (set)
241 6	<b>4812 310 18757</b>	Holder glasses KIT wh
241 8	<b>4812 466 68553</b>	Spacer cap set
242 0	<b>4812 310 28136</b>	Basket lower KIT
242 1	<b>4812 528 88069</b>	Wheel,basket lower wh
242 4	<b>4812 466 48091</b>	Fixation gr
243 5	<b>4819 310 39859</b>	Cutlery basket KIT
243 6	<b>4812 458 18996</b>	Grille wh
261 0	<b>4812 462 79831</b>	Rail telescope, inner
261 1	<b>4812 462 79768</b>	Cap rail
261 2	<b>4812 462 79832</b>	Cap rail ahead
263 0	<b>4819 520 18013</b>	Ball cage cpl.
263 1	<b>4812 310 48026</b>	Service kit balls plastic
265 0	<b>4812 404 48637</b>	Basket adjustm. cpl.
265 2	<b>4812 404 48638</b>	Grip basket adjustment
301 0	<b>4812 453 72459</b>	Control panel ,ADP4520WH
303 1	<b>4812 460 38148</b>	Plate,handle
331 0	<b>4812 413 59155</b>	Knob
332 0	<b>4812 410 29163</b>	Button ,START
332 3	<b>4812 410 29166</b>	Button ON/OFF
350 2	<b>4812 381 28068</b>	Light guide
400 0	<b>4812 361 58334</b>	Motor +SP,50Hz,per.HP-PNT
421 0	<b>4812 121 18158</b>	Interf.filter
430 0	<b>4812 360 18508</b>	Pump,draining cpl.

Pos. No.	12NC Code	Description
430 1	<b>4812 466 68689</b>	Gasket
450 0	<b>4812 259 28684</b>	Heating element
480 0	<b>4812 321 28425</b>	Cable harness ,(EBL) with LS6
480 3	<b>4812 401 18418</b>	Protector f.wiring
490 0	<b>4819 321 18136</b>	Cable,mains 2m SA
490 1	<b>4812 321 28367</b>	Strain relief
521 0	<b>4812 218 38209</b>	User board ,(UCB)
521 8	<b>4812 530 78066</b>	Axle ,program knob grey
571 0	<b>4812 281 28379</b>	Valve inlet
575 0	<b>4812 281 28361</b>	Regen.valve
583 0	<b>4812 271 28407</b>	Switch diaphragm
616 0	<b>4812 281 18047</b>	Contact,reed salt
616 1	<b>4812 271 58161</b>	Contact,reed rinsing agent
621 0	<b>4819 410 29004</b>	Switch ON/OFF
633 0	<b>4812 271 38355</b>	Microswitch door
680 0	<b>4812 418 68155</b>	Combidosage
680 1	<b>4812 466 68495</b>	Gasket
681 1	<b>4812 466 68497</b>	Gasket
681 2	<b>4812 440 18975</b>	Flap
682 0	<b>4812 466 68496</b>	Gasket
691 0	<b>4812 282 68012</b>	Feeler NTC
701 0	<b>4819 530 28928</b>	Hose, inlet 2m
701 1	<b>4812 310 18302</b>	Yoke
701 2	<b>4822 480 50159</b>	Sieve inlet
710 0	<b>4812 418 68128</b>	Monoblock
710 2	<b>4819 310 38536</b>	Threaded ring
710 3	<b>4819 466 69562</b>	Gasket set
714 0	<b>4812 462 78993</b>	Threaded cap
716 0	<b>4812 418 68147</b>	Reg.dosage
716 1	<b>4812 466 68475</b>	Gasket
716 2	<b>4812 462 78994</b>	Cover
717 1	<b>4812 462 79793</b>	Stopper
721 1	<b>4812 360 68347</b>	Spray arm lower. cpl.
722 0	<b>4812 360 68348</b>	Spray arm upper wh
722 2	<b>4812 360 68349</b>	Spray arm 2nd level cpl. wh
723 0	<b>4812 360 68351</b>	Douche ceiling
726 1	<b>4812 530 29118</b>	Tube assembly cpl.
726 2	<b>4812 505 18208</b>	Nut
743 0	<b>4812 511 48171</b>	Condenser
743 1	<b>4812 530 28102</b>	Hose, inlet
743 3	<b>4812 505 18364</b>	Nut
743 4	<b>4812 530 28807</b>	Hose 9x1,5x270+10
743 7	<b>4812 466 68514</b>	Gasket
751 0	<b>4812 418 18338</b>	Water collector
755 0	<b>4812 530 29119</b>	Bend
755 2	<b>4812 530 48148</b>	Tray,leak
756 0	<b>4812 360 58099</b>	Floater
761 0	<b>4812 480 58122</b>	Sieve fine
761 2	<b>4812 418 18337</b>	Cover sieve
761 3	<b>4812 418 18341</b>	Cover
761 4	<b>4812 530 58141</b>	O-Ring
763 0	<b>4812 480 58123</b>	Sieve coarse
781 0	<b>4812 530 29113</b>	Hose,draining
781 3	<b>4812 281 28417</b>	Flap non-return
783 4	<b>4812 530 28888</b>	Hose

## Spare part list

**Model** ADP 4520 WH  
**Service No.** 851176310810  
**Version** 851176310810

---

Pos. No.	12NC Code	Description
783 6	<b>4812 530 28796</b>	Hose 10x3x180+10
791 0	<b>4812 532 68099</b>	Gasket
791 2	<b>4812 530 58093</b>	Gasket
791 4	<b>4812 466 68503</b>	Gasket
791 5	<b>4812 466 68504</b>	Gasket
901 0	<b>4822 401 10258</b>	Clamp,hose 10-18 mm
901 1	<b>4812 401 18424</b>	Strap 050,0
901 2	<b>4812 401 18157</b>	Strap 32-50/9 C61
901 5	<b>4812 401 48573</b>	Strap 028,6
904 4	<b>4812 462 79659</b>	Threaded cap
910 1	<b>4812 502 18394</b>	Screw 3,5x14-H
910 2	<b>4812 502 18363</b>	Screw 4,0x12-H
910 3	<b>4812 502 18527</b>	Screw 4x15 T20
910 4	<b>4812 502 18385</b>	Screw M3,5x8-T15M
910 5	<b>4812 502 18393</b>	Screw 3,5x9-1 Tx15
910 7	<b>4812 502 18397</b>	Screw INOX A2 M 5X12
910 8	<b>4812 502 18389</b>	Screw 5x20 T20
910 9	<b>4812 401 18425</b>	Screw 2,5x18-H
964 0	<b>4812 466 68536</b>	Gasket housing ri/le
964 1	<b>4812 466 68469</b>	Gasket housing upper
993 0	<b>4819 530 29028</b>	Bow
993 5	<b>4822 532 80216</b>	Funnel salt

## Exploded view

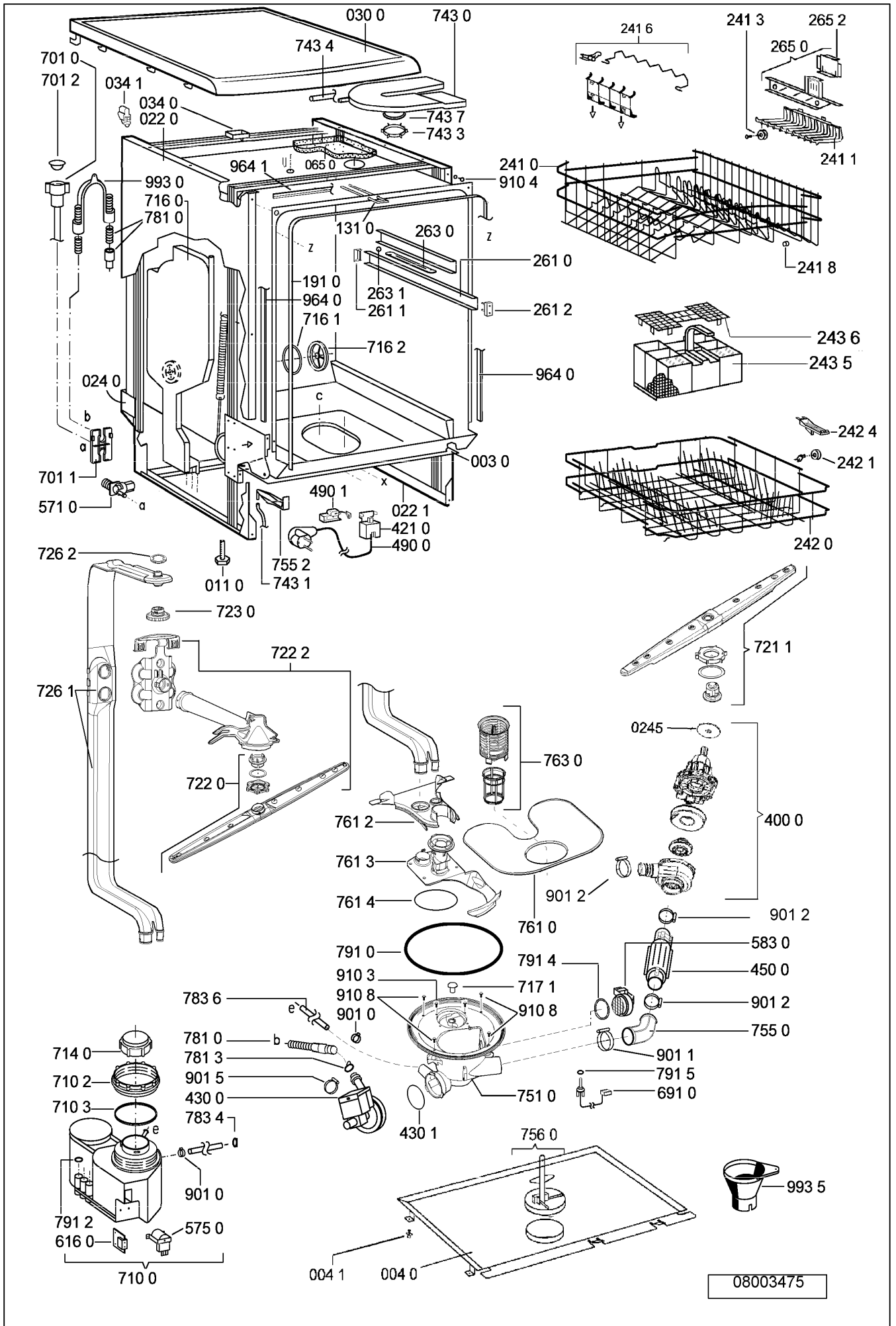

**Exploded view**

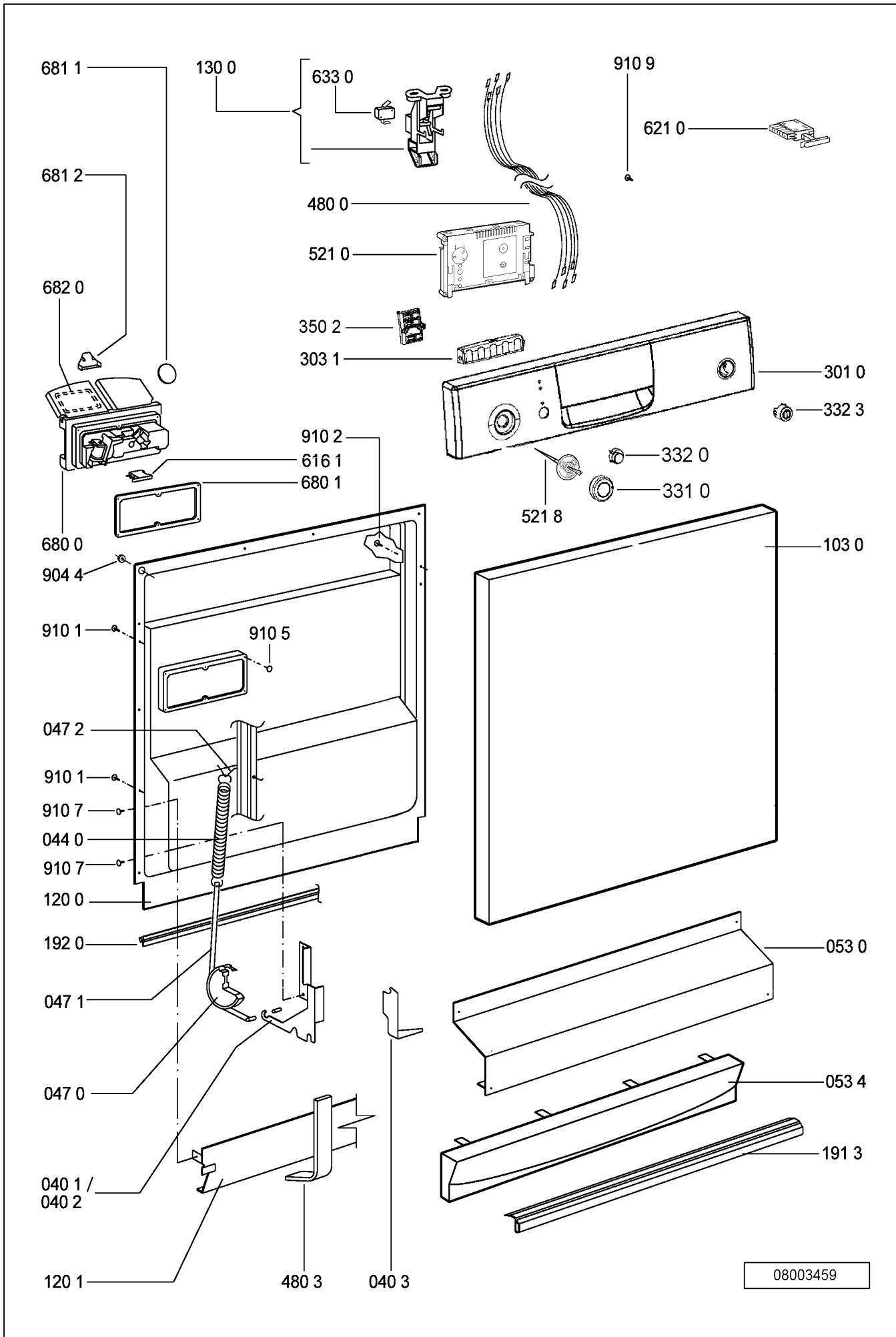

08003459



## Circuit diagram

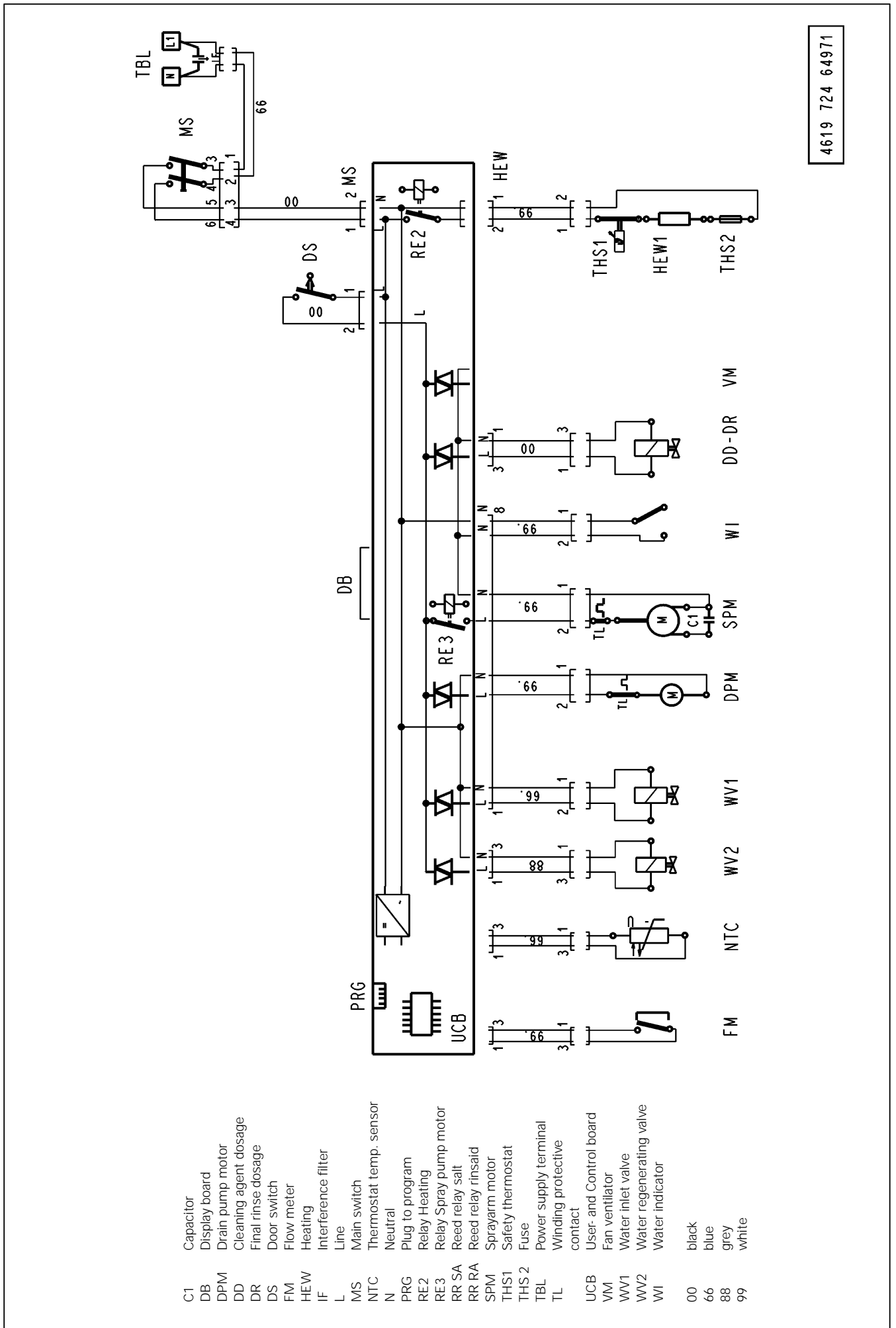



## Text/Legend

### **Test procedure for SERVICE-TEST-PROGRAM Point dishwashers appliances with and without 7 Segment Display and an Integrated Board.**

Switch on the appliance.

1. If there is a defective component indicated, open up the control board (CB).
2. Check the component.  
Unplug the indicated component from the control board (CB) and check it by using an ohmmeter.  
If the resistance is not correct, check the cables to the component and check the component itself.
3. Visually check the control board (CB).
4. At the end of the repair start the appliance and delete the failure (press in the start button for more the 1.5 sec). After this, start the test program again to see that the failure is solved.

More details: see following pages.

#### **Attention:**

**Danger** of short circuit. Short circuits on components can damage the control board (CB).

If electronic boards are wet, do not switch the appliance on.

To check the appliance, plug in the appliance.

Failures, which occurred during the program will be stored and indicated by flashing the start LED.

The failure will be indicated and can be related to the failure table.

To erase the failures, you must push the start button longer than 1.5 seconds.

The failures:

F1 NTC break

F9 continuous water inlet

are checked and indicated immediately after start of the program.

Therefore these failures have to be solved before starting the test program.

When these failures are not solved, the test program does not run.

The electrical components get their voltage via triac from the control board (CB). To test the voltage the voltmeter must be connected in parallel to the component (the component must be connected). If the component is disconnected, then the output voltage from the control board (CB) is reduced.

**After starting a program this program is locked. That means neither by unplugging/switching off the appliance nor by setting to another program, the first set program cannot be changed. Changing of the program is only possible by pushing the start button again for longer than 1.5 sec..**

**Attention:** New service control boards start at first with the service test program. This test program is without back rinsing. Dangerous for overfilling the appliance, in case the appliance is not empty. By running the test program or another program a second time, the back rinsing will be carried out as usual.

## Text/Legend

### Handling of failures

- F1. NTC break  
Temperature out of the normal value (-3°C till +85°C)  
- Temperature inside higher than +85°C  
- NTC defective  
- Dishwasher is frozen, less than -3°C  
If the temperature is less than -3°C, fill the appliance with a cup of warm water to warm it up before you start it..
- F2. **Water Leakage**  
- **Water is in the drip tray**  
**Floater (LS6) switches off the WV1 and the electronic switches on the DPM until WI reports that it is empty.**
- F3. Heating System Defective  
Indicated after app. 25 minutes (1. check after 5 min., after that follow 2 more checks, before the failure is indicated)  
- Heats too slowly (less than 1.5 °C in 10 min.)  
- Heating (HEW) defective  
- Relays (RE2) on control board (CB) is defective  
- NTC - resistance fluctuation
- F4. Draining Failure  
Drain pump starts and after 4 min. the WI detects that it is "not empty"  
- Drain pump (DPM) defective  
- Siphon closed  
- Control board (CB) defective  
- WI defective. (doesn't switch back anymore)
- F6. Water Tap Closed  
Water valve (WV1) is switched on but flow meter (FM) sends no impulses (less than 10 imp. in 10 sec.) and the water indicator (WI) is off (empty)  
- Water tap closed  
- Water inlet hose blocked  
- Water inlet valve (WV1) defective
- F7. Flow Meter Failure  
Water inlet valve (WV1) is switched on and the water indicator (WI) is on (full).  
- Flow meter (FM) sends too few impulses (less than 10 imp. in 10 sec.)  
- Water tap closed during water inlet  
- Water inlet hose blocked  
- Water inlet valve (WV1) defective  
- Flow meter (FM) defective









**Text/Legend**

- F8. Water Level Failure.  
Failures are supervised over the whole program.  
Spray pump works, the WI switches more than 20 times in 2 minutes back.  
- WI defect? Should switch on after approx. 1 Ltr  
- Sieve blocked  
- Water strongly foams  
- Pot has over turned and has filled with spray water  
- No stable spray pump (SPM) pressure.
- F9. Continuous Water Inlet  
Water inlet valve (WV1) is switched off, water indicator (WI) on, flow meter (FM) sends impulses (more than 10 imp. in 10 sec.)  
- Water inlet valve (WV1) mechanically not closed  
- Triac (CB) permanently switched on. (short circuit)  
Reaction: interval 30 sec. drain pump on / 20 sec. drain pump off in interval
- FA. WI Failure  
If the electronic signal of the Flow meter has been received for the 3.4 Ltr. of water on permanent wash system and the WI signal "Water in the sump" is missing then an failure is recorded.
- FE. EPROM Failure  
After the start of the test programme the EPROM is immediately checked for errors and an error is displayed if any are found.

**Text/Legend**

**Failure Display POINT**

**Appliances with 1 and 2-digit 7 Segment Display and without 7 Segment Display**

Alarm / Failure	Failure code, Indication in test program when a failure occurs
	Shown with 7 segment display or without 7 segment display
<b>F1 NTC-Failure</b>	 1 x flash 1s Pause 1 x flash.....
<b>F3 Failure in Heating System</b>	 3 x flashes 1s Pause 3 x flashes.....
<b>F4 Draining Failure</b>	 4 x flashes 1s Pause 4 x flashes.....
<b>F6 Water Tap closed</b>	 6 x flashes 1s Pause 6 x flashes.....
<b>F7 Flow Meter Failure</b>	 7 x flashes 1s Pause 7 x flashes.....
<b>F8 Water Level Failure</b>	 8 x flashes 1s Pause 8 x flashes.....
<b>F9 Continuous Waterinlet</b>	START  9 x flashes 1s Pause 9 x flashes.....
<b>FA WI-Failure</b>	START  11 x flashes 1s Pause 11 x flashes.....
<b>FE EPROM Failure</b>	START  15 x flashes 1s Pause 13 x flashes.....

 LED flashing

## Text/Legend

**Attention:**

If you can't start the test program (Start button doesn't flash), normally there is one of the following failures detected: F1 or F9.

When these failures are not solved before, the test program will not run. After solving the failure you must "sign" (erase) the failure.

If a failure is indicated directly after you switch on the appliance. Then fix the mistake, erase failure and start the test program again (see following start procedure).

**Start procedure****Start the test program if there is no failure indicated**

1. Turn OFF appliance at the Mains.
2. Select program position 1.
3. Push start button and hold it.
4. Turn On appliance still holding the start button.
5. Release the start button when the Start-LED flashes.
6. Start the test program by pushing the start button again.
7. Failure indication.
8. Repair the failure.
9. Solve the failure by pushing the start button for longer than 1.5 sec.
10. Start the test program again, to see, if the failure really is solved.

**Text/Legend**

**Test Programme**

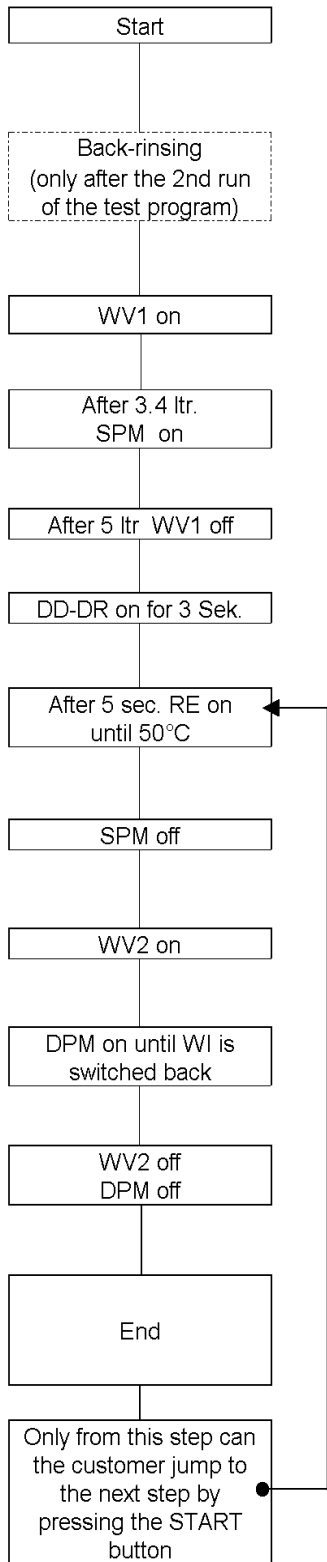

Remarks

The test program runs to the failure position and stops or, if there is no failure, it runs to the end.

To leave the test program push the start button for longer than 1.5 second's.

Not enough salt or rinse aid will not stop the running of the appliance.

When the failure position is reached the failure indication is indicated on the page "Failure Codes"

**Attention:**

If you can't start the test program (Start button doesn't flash), normally there is one of the following failures detected: F1, or F9

When these failures are not repaired, the test program will not run. After solving the failure you must "sign" (erase) the failure.