



Philips Domestic Appliances and Personal Care

Service Manual

PRODUCT INFORMATION

- This product meets the requirements regarding interference suppression on radio and TV.
- After the product has been repaired, it should function properly and has to meet the safety requirements as officially laid down at this moment.

TECHNICAL INFORMATION

- Colour /A : Ice Blue
- /B : Mauve metallic
- Version /C : 2000 W logo
- Colour /F : **Black granite**
- Maximum air displacement : 37 l/sec.
- Maximum vacuum water column : 310 cm
- Power consumption (IEC) 230 V : 1500 W
- Duststorage capacity : 3 L
- Type number dustbag : FC8021
- Cord length (depends on version) : 7 metres
- Filter system : Paper dustbag
: Exhaust AFS air filter
: Motor inlet filter
- Dimensions of cleaner : 460 x 315 x 270 mm
- Dimensions of packaging : 595 x 395 x 295 mm
- Net weight : 5.88 kg
- Gross weight : 9.135 kg

■ = changed

OPTIONAL (accessories)

- FC8021 S-bags
- FC8030 AFS-filter
- FC8031 HEPA Air Filter
- FC8034 Upgrade kit Active Carbon Filter
- HR6988 Turbo brush nozzle
- HR8040 Polishing nozzle

DISASSEMBLY- AND RE-ASSEMBLY ADVISE

- Open the appliance, first remove the exhaust filter grille (item 20), and then remove the 2 screws - **C** of the switch control panel (item 15).
- Undo and remove the 9 screws - **C** in the upper housing (item 8). You will require a screwdriver with a 14.5 cm-long shank for this. Depending on the version screwdriver 9965 000 08332 for cross head or onwards 0234 screwdriver 4322 009 08490 for T15 can be used.
- The component configuration shown in the exploded view may differ in case of specific versions. The components are distinguished by means of code numbers.
- When the repair is finished, check whether all functions of the appliance work properly.
- To disassemble the cord winder, use TORX screwdriver no. T10, which is one of a set consisting of T20; T15; T10; T9; T8; T7 and T6 (code number 4822 395 50145).

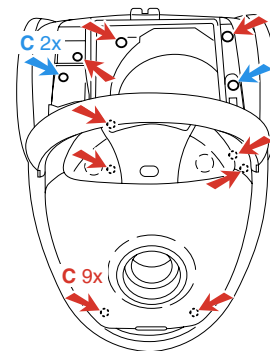

REPAIR INSTRUCTION

- **Item 4**, cotton dustbag, is used in countries in which paper dustbags are not available.
- If the reel half spring unit is replaced, shaft **A** must be lubricated with **silicone grease**. Do not apply any silicone grease to or spill any grease on terminals (43) or conductors (42).
- **Item 40** is provided with a long cord-winder spring, but both long and short cords can be used in combination with this spring. (L = 9.3 m)
- Depending on the original cord, the spare cord must be shortened to the length of the original cord.
- The cord winder spring must be tensioned to the maximum level and then be rewound approx. 1.5 turn
- **Item 13**, air valve, opens to cool the motor if the air displacement is too low or if the airflow is blocked.
- To adjust the telescopic tube (**item 59**) to the required length, push the adjustment collar in the direction of the arrow while sliding the top section of the telescopic tube into or out of the lower section.
- If the function of the electronic control unit (**item 12**) is not required, the Triac must be short-circuited in the manner shown in the circuit diagram.
- When the vacuum cleaner is used to suck up fine dust the pores of the dustbag may become clogged, causing the passage of air through the dustbag to become obstructed. As a result, the dustbag-full indicator will indicate that the dustbag needs to be replaced, eventhough the dustbag is not full at all.

 = changed

- Due to introduction of a **new switch** (item 11) 0320 onwards, which is not interchangeable with the old switch soldered on the PCB (item 12).
- The switch lever assy (item 11a) is also modified.

To recognize the switches:

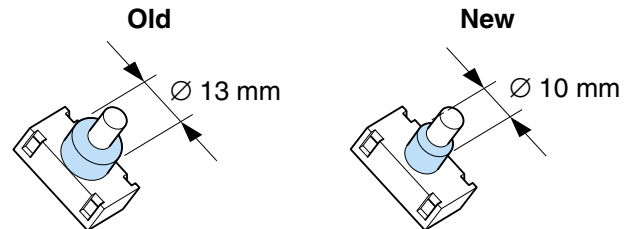

To replace the knobs:

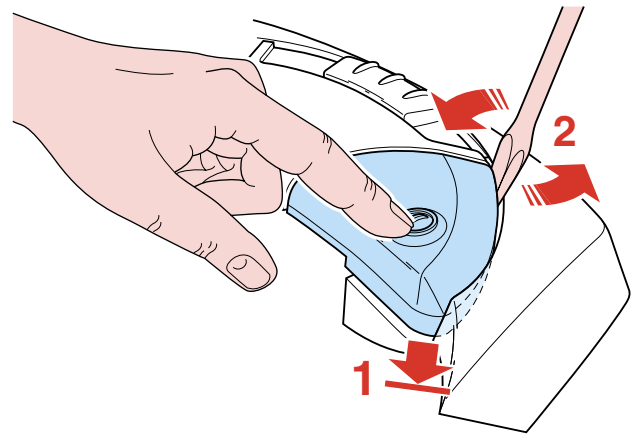

New spares are:

11	Switch soldered version	- 4322 006 50600
11a	Switch lever assy	- 4322 009 08980
parts of 15	Switch and Cord winder knob	- 4322 009 09000

ELECTRICAL DIAGRAM

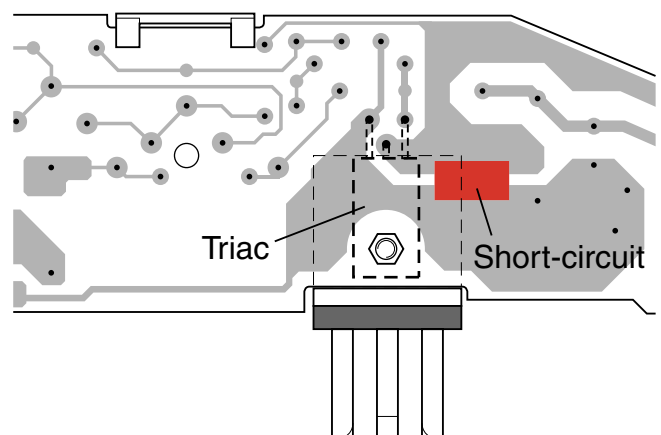
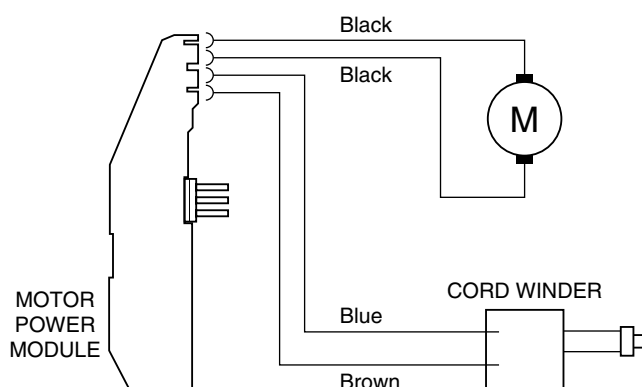

PARTS LIST

FC9102 /A /B /C /F

Pos	Service code	Description
1	4322 009 08070	Dust cover Ice Blue /A
	4322 009 08130	Dust cover Mauve met. /B
	4322 009 09100	Dust cover Black granite /F
2	4322 003 18280	Dust cover lock grey
3	4322 003 18150	Dustbag holder
4	4822 480 10113	S-paper dustbags FC8021
	4322 004 93290	Cotton dustbag
5	4322 003 18300	Cordwinder lever
6	4322 001 73310	Sealing rim
7	4322 005 12550	Dustbag detector
8	4322 003 18050	Upper housing l.grey
8a	4322 003 20410	Clamp upper/lower housing
9	4322 000 37300	Triple filter
10	4322 009 07040	Grill + triple filter
11	4322 006 21480	Switch soldered version
	4322 006 50600	Switch sold. vers. 0320 onwards
11a	4322 009 08420	Switch lever assy
	4322 009 08980	Switch lever assy 0320 onwards
12	4322 006 22560	PCB slide turn 230V
13a	4322 005 12200	Dustbag full indicator
13b	4322 005 12210	Air valve
14	4322 003 18090	Handle l.grey
15	4322 009 08140	Panel slide Ice Blue /A
	4322 009 08200	Panel slide Mauve met. /B
	4322 009 09080	Panel slide Black granite /F
16	4322 003 17890	Lower housing l.grey
17	4322 003 18100	Handle lock
18	4322 000 37450	Silencer 4 wall
19	4322 005 12180	Caster assy l.grey
20	4322 009 08210	Exhaust grille Ice Blue /A
	4322 009 08260	Exhaust grille Mauve met. /B
	4322 009 09090	Exhaust grille Black granite /F
21	4322 000 37460	Exhaust diffusor
22	4322 004 92910	Electr.static filter FC8030
23	4322 001 73280	Filter sealing
24	4322 003 18000	S-class sealing
25	4322 000 37420	Silencer 1 wall
26	4322 000 37430	Silencer 2 bottom
27	4322 003 18070	Cord outlet l.grey
28	4322 003 18910	Rear wheel lock red
29	4322 003 11990	Receipt. housing A.C.
30	4322 003 17950	Rear wheel l.grey
	4322 003 23160	Rear wheel Black granite /F
31	4322 001 73300	Motor buffer back

Pos	Service code	Description
32	4322 003 18040	Inlet sealing
33	4322 003 18010	Motor cap top
34	4322 003 18020	ANS disc
35	4322 001 73290	Motor bufferring front
36	4322 009 06430	Motor A 1441 230V
37	4322 000 37440	Silencer 3 ans
38	4322 003 18030	Motor cap bottom
40	4322 009 07940	Reel half spring unit (L = 9m)
41	4322 001 72360	Brake tyre
42	4322 009 07950	Reel half contact unit
43	4322 009 07970	Contact ring plate
44	4322 006 01440	Argentina L = 9.3 m
	4322 006 01760	Australia L = 9.3 m
45	4322 006 01680	Taiwan L = 6.3 m
46	4322 006 01720	U.K. / H.K. L = 9.3 m
47	4322 006 01410	Euro 4.8 mm pins L = 9.3 m
48	4322 006 01670	Swiss L = 9.3 m
49	4322 006 01460	Italy L = 9.3 m
50	4322 003 18850	C-bend B1
51	4322 005 12720	C-bend B1 hose sw assy
54	4322 007 16000	Leaf spring assy
55	4322 004 22570	Plumeau assy
56	4322 003 18870	Crevice nozzle
57	4322 005 12530	Acc. bridge assy
59	4322 004 22510	Telesc. tube st. silver complete
60	4322 001 99120	Tube bush
61	4322 007 45550	Tube spring
62	4322 004 22560	Small nozzle
63	4322 004 22490	R&C nozzle standard l.grey
A	5322 390 20011	Silicon grease for shaft
B	4322 002 82550	Screw 3.5 x 12 T10
C	4322 002 82080	Screw 3.5 x 19

■ = changed

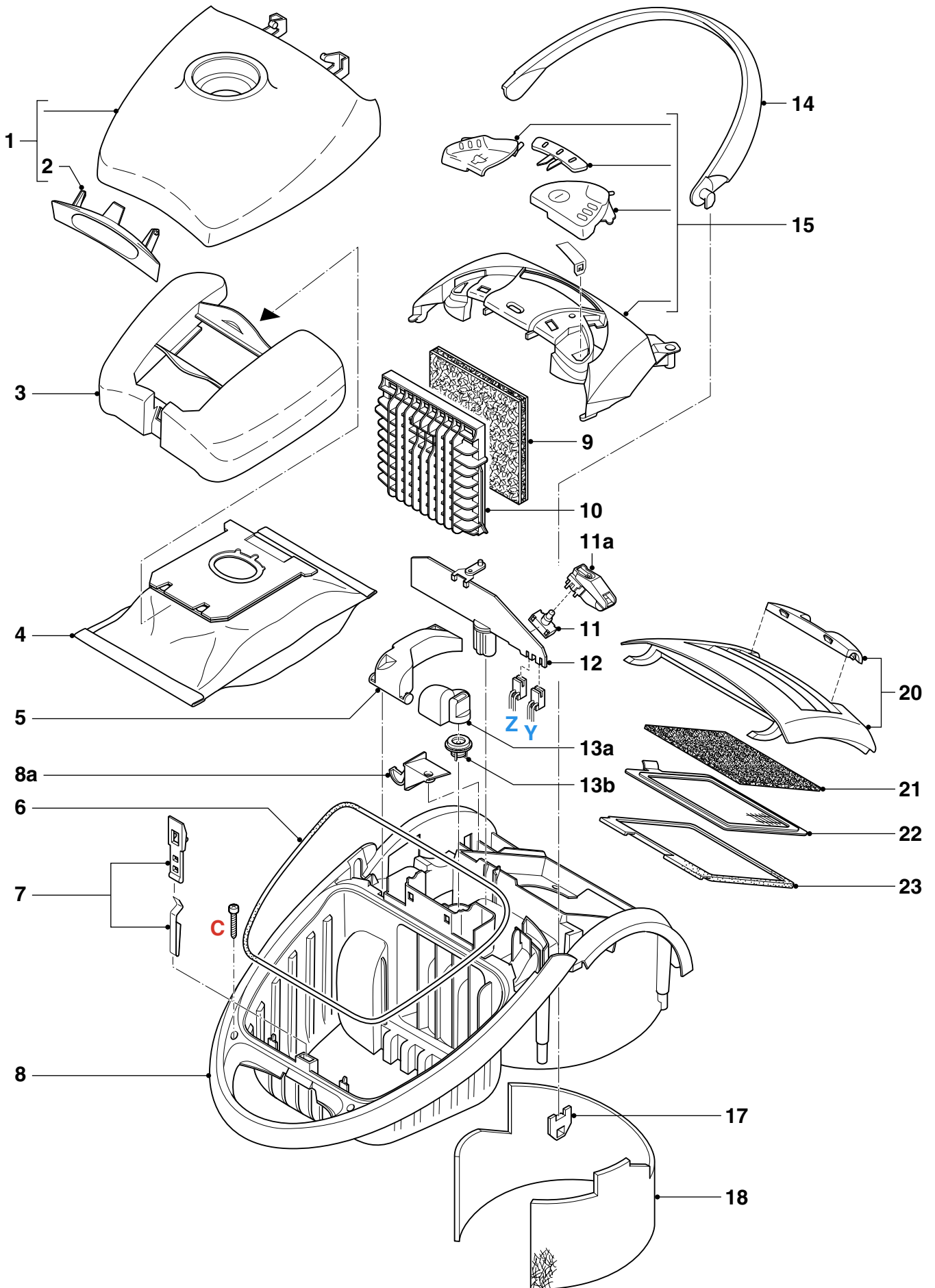

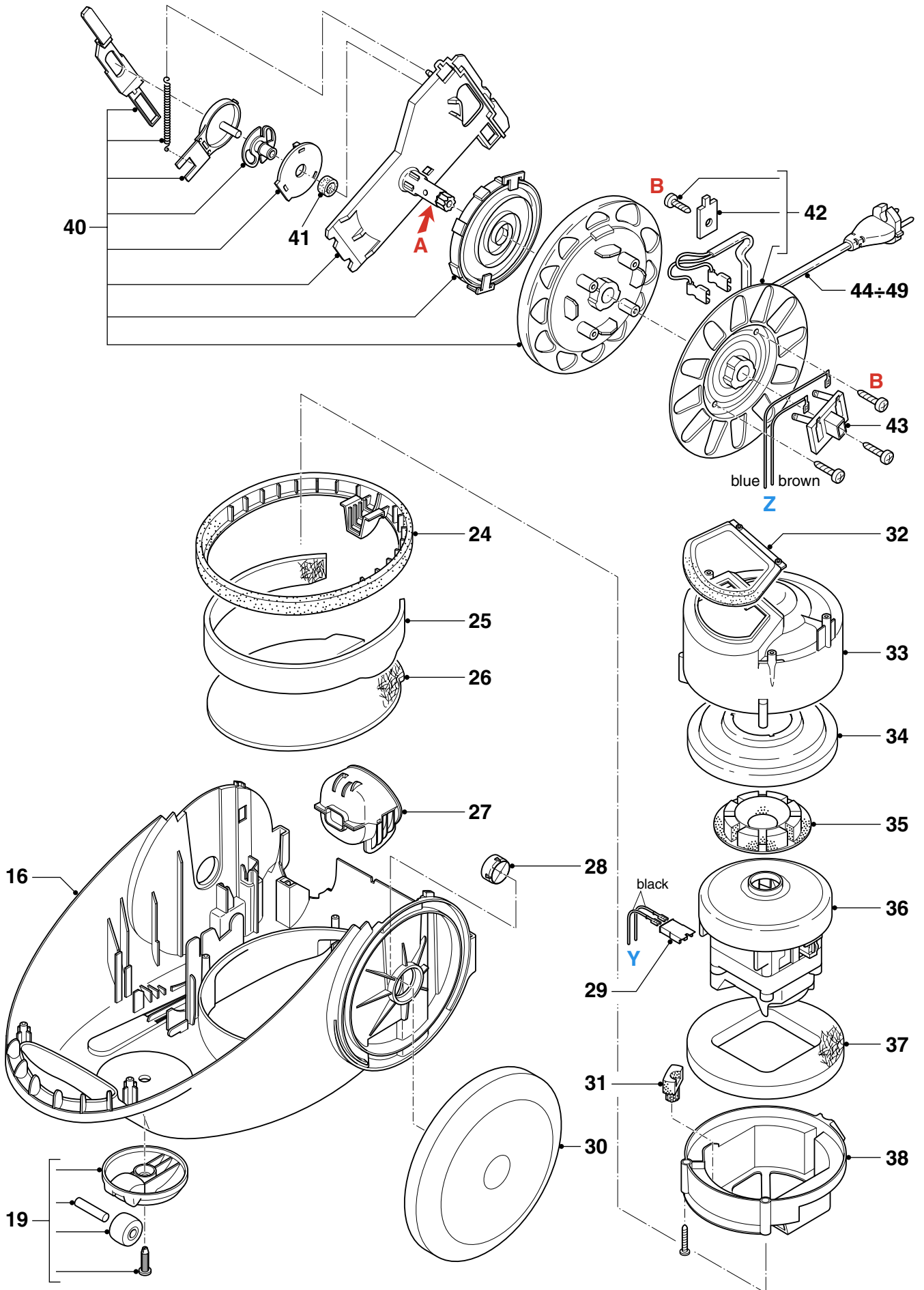

EXPLODED VIEW

FC9102 /A /B /C /F

