

SERVICE MANUAL



Color Inkjet Printer

EPSON Stylus Photo R200/R210



EPSON®

Notice

- All rights reserved. No part of this manual may be reproduced, stored in a retrieval system, or transmitted in any form or by any means electronic, mechanical, photocopying, or otherwise, without the prior written permission of SEIKO EPSON CORPORATION.
- The contents of this manual are subject to change without notice.
- All effort have been made to ensure the accuracy of the contents of this manual. However, should any errors be detected, SEIKO EPSON would greatly appreciate being informed of them.
- The above notwithstanding SEIKO EPSON CORPORATION can assume no responsibility for any errors in this manual or the consequences thereof.

EPSON is a registered trademark of SEIKO EPSON CORPORATION.

*General Notice: Other product names used herein are for identification purpose only and may be trademarks or registered trademarks of their respective owners.
EPSON disclaims any and all rights in those marks.*

Copyright © 2003 **SEIKO EPSON CORPORATION.**
Imaging & Information Product Division
TP • CS Quality Assurance Department

PRECAUTIONS

Precautionary notations throughout the text are categorized relative to 1) Personal injury and 2) damage to equipment.

DANGER Signals a precaution which, if ignored, could result in serious or fatal personal injury. Great caution should be exercised in performing procedures preceded by DANGER Headings.

WARNING Signals a precaution which, if ignored, could result in damage to equipment.

The precautionary measures itemized below should always be observed when performing repair/maintenance procedures.

DANGER

1. ALWAYS DISCONNECT THE PRODUCT FROM THE POWER SOURCE AND PERIPHERAL DEVICES PERFORMING ANY MAINTENANCE OR REPAIR PROCEDURES.
2. NO WORK SHOULD BE PERFORMED ON THE UNIT BY PERSONS UNFAMILIAR WITH BASIC SAFETY MEASURES AS DICTATED FOR ALL ELECTRONICS TECHNICIANS IN THEIR LINE OF WORK.
3. WHEN PERFORMING TESTING AS DICTATED WITHIN THIS MANUAL, DO NOT CONNECT THE UNIT TO A POWER SOURCE UNTIL INSTRUCTED TO DO SO. WHEN THE POWER SUPPLY CABLE MUST BE CONNECTED, USE EXTREME CAUTION IN WORKING ON POWER SUPPLY AND OTHER ELECTRONIC COMPONENTS.
4. WHEN DISASSEMBLING OR ASSEMBLING A PRODUCT, MAKE SURE TO WEAR GLOVES TO AVOID INJURIER FROM METAL PARTS WITH SHARP EDGES.

WARNING

1. REPAIRS ON EPSON PRODUCT SHOULD BE PERFORMED ONLY BY AN EPSON CERTIFIED REPAIR TECHNICIAN.
2. MAKE CERTAIN THAT THE SOURCE VOLTAGES IS THE SAME AS THE RATED VOLTAGE, LISTED ON THE SERIAL NUMBER/RATING PLATE. IF THE EPSON PRODUCT HAS A PRIMARY AC RATING DIFFERENT FROM AVAILABLE POWER SOURCE, DO NOT CONNECT IT TO THE POWER SOURCE.
3. ALWAYS VERIFY THAT THE EPSON PRODUCT HAS BEEN DISCONNECTED FROM THE POWER SOURCE BEFORE REMOVING OR REPLACING PRINTED CIRCUIT BOARDS AND/OR INDIVIDUAL CHIPS.
4. IN ORDER TO PROTECT SENSITIVE MICROPROCESSORS AND CIRCUITRY, USE STATIC DISCHARGE EQUIPMENT, SUCH AS ANTI-STATIC WRIST STRAPS, WHEN ACCESSING INTERNAL COMPONENTS.
5. DO NOT REPLACE IMPERFECTLY FUNCTIONING COMPONENTS WITH COMPONENTS WHICH ARE NOT MANUFACTURED BY EPSON. IF SECOND SOURCE IC OR OTHER COMPONENTS WHICH HAVE NOT BEEN APPROVED ARE USED, THEY COULD CAUSE DAMAGE TO THE EPSON PRODUCT, OR COULD VOID THE WARRANTY OFFERED BY EPSON.

About This Manual

This manual describes basic functions, theory of electrical and mechanical operations, maintenance and repair procedures of the printer. The instructions and procedures included herein are intended for the experienced repair technicians, and attention should be given to the precautions on the preceding page.

Manual Configuration

This manual consists of six chapters and Appendix.

CHAPTER 1. TROUBLESHOOTING

Describes the step-by-step procedures for the troubleshooting.

CHAPTER 2. DISASSEMBLY / ASSEMBLY

Describes the step-by-step procedures for disassembling and assembling the product.

CHAPTER 3. ADJUSTMENT

Provides Epson-approved methods for adjustment.

CHAPTER 4. MAINTENANCE

Provides preventive maintenance procedures and the lists of Epson-approved lubricants and adhesives required for servicing the product.

APPENDIX Provides the following additional information for reference:

- Electrical circuit boards schematics

Symbols Used in this Manual

Various symbols are used throughout this manual either to provide additional information on a specific topic or to warn of possible danger present during a procedure or an action. Be aware of all symbols when they are used, and always read NOTE, CAUTION, or WARNING messages.



Indicates an operating or maintenance procedure, practice or condition that is necessary to keep the product's quality.



Indicates an operating or maintenance procedure, practice, or condition that, if not strictly observed, could result in damage to, or destruction of, equipment.



May indicate an operating or maintenance procedure, practice or condition that is necessary to accomplish a task efficiently. It may also provide additional information that is related to a specific subject, or comment on the results achieved through a previous action.



Indicates an operating or maintenance procedure, practice or condition that, if not strictly observed, could result in injury or loss of life.



Indicates that a particular task must be carried out according to a certain standard after disassembly and before re-assembly, otherwise the quality of the components in question may be adversely affected.

Revision Status

Revision	Issued Date	Description
A	January 29, 2004	First Release

CONTENTS

Chapter 1 TROUBLESHOOTING

1.1 Overview	8
1.2 Troubleshooting with LED/LCD Indications and Status Monitor 3 Message	9
1.3 Unit Level Troubleshooting	14

Chapter 2 DISASSEMBLY AND ASSEMBLY

2.1 Overview	31
2.1.1 Precautions	31
2.1.2 Tools	32
2.1.3 Pre-Shipment Checks	32
2.2 Caution regarding assembling/disassembling the printer mechanism, and how to ensure the quality of reassembled product	34
2.3 Disassembly	36
2.3.1 Paper Support Assy./Housing (left/right)/Stacker Assy. removal	37
2.3.2 Housing (frame)/Panel Assy./Panel Board removal	39
2.3.3 ASF Unit removal	40
2.3.4 CR Motor removal	42
2.3.5 Print Head removal	43
2.3.6 Porous Pad, Paper Guide, Front removal	44
2.3.7 Board, Main removal	45
2.3.8 Holder, Shaft Unit removal	46
2.3.9 APG Unit removal	49
2.3.10 Paper Guide, Upper removal	50
2.3.11 Carriage Unit removal	51
2.3.12 Printer Mechanism/Housing (lower) removal	57
2.3.13 Power Supply Unit removal	61
2.3.14 CDR Guide Assy. removal	62
2.3.15 Ink System Unit removal	64
2.3.16 Paper Guide, Front/Roller EJ Assy. removal	67
2.3.17 PF Motor removal	71

Chapter 3 ADJUSTMENT

3.1 Adjustment Items and Overview	73
3.1.1 Servicing Adjustment Item List	73
3.1.2 Replacement Part-Based Adjustment Priorities	77
3.2 Adjustment by using adjustment program	79
3.2.1 Market Setting	79
3.2.2 USB ID Input	79
3.2.3 Head ID Input	79
3.2.4 Head Angular Adjustment	80
3.2.5 Bi-d Adjustment	80
3.2.6 PW Sensor Adjustment	81
3.2.7 First Dot Adjustment	81
3.2.8 Offset Input for CR Motor Calorific Limitation	82
3.2.9 A4 Normal Paper Print	82
3.2.10 A4 Photo Quality Inkjet Paper Print	82
3.2.11 A4 Photo Paper/ Glossy Photo Paper print	82
3.3 Adjustment Except Adjustment Program	83
3.3.1 PG Adjustment	83

Chapter 4 MAINTENANCE

4.1 Overview	87
4.1.1 Cleaning	87
4.1.2 Service Maintenance	87
4.1.3 Lubrication	89

Chapter 5 APPENDIX

5.1 Exploded Diagram	97
5.2 Electrical Circuits	97

CHAPTER

1

TROUBLESHOOTING

1.1 Overview

This chapter describes how to identify troubles in two levels: unit level repair and component level repair. Refer to the flowchart in this chapter to identify the defective unit and perform component level repair if necessary. This chapter also explains motor coil resistance, Sensor specification and error indication.

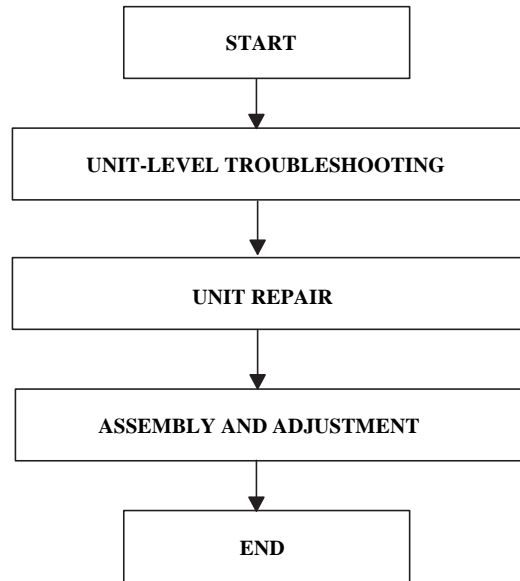

Figure 1-1. Troubleshooting Flowchart

Table 1-1. Motor, Coil Resistance

Motor	Location	Check Point	Resistance
PF Motor (Same as ASF/ Pump Motor)	CN6	Pin 1 and 3 Pin 2 and 4	3.0Ω ±10% (25°C/phase)

Since "CR Motor" and APG Motor are DC motors, the resistance among the electric poles varies. Therefore, judge if it is normal or abnormal based on if there is operation of the motor or not; the resistance values cannot be used to judge the abnormality. However, it is difficult to judge accurately, if it is not clear, replace the motor.

Table 1-2. Sensor check point

Sensor name	Location	Check point	Signal level	Switch mode
PE Sensor	CN9	Pin 1 and 2	More than 2.4V	Off : No paper
			Less than 0.4V	On : Detect paper
PG Sensor	CN14	Pin 1 and 2	More than 2.4V	Off : Anywhere of PG
			Less than 0.4V	On : In process of switching PG
Star Wheel Sensor	CN11	Pin 1 and 2	-	On : ASF mode
			-	Off : CDR mode
CDR Sensor	CN11	Pin 3 and 4	-	Off : No CDR Tray
			-	On : Detect CDR Tray

1.2 Troubleshooting with LED/LCD Indications and Status Monitor 3 Message

This section describes the LED/LCD indication, the STM3 message and the error condition when the printer detects an error in each operation such as the power on, the paper loading/feeding and the ink absorption operation. (As for the screen shot in STM3 message, it's used screen shot of Stylus Photo R300/310 as a substitute for that of Stylus Photo R200/210.)

Table 1-3. LED Indication and STM3



Printer status	LED indication			STM3 message	Condition for error detection
	Power	Paper	Ink		
Communication Error	--	--	--		This error is detected when the printer cannot communicate with the PC properly.
Error before Initial Ink Charge	Blink	--	On		This error is detected when a defective cartridge is installed in the printer which the Initial Ink Filling is not done yet.

Table 1-3. LED Indication and STM3



Printer status	LED indication			STM3 message	Condition for error detection
	Power	Paper	Ink		
Error before ink replacement Cleaning	--	--	On		This error is detected when replacing the Ink Cartridge, if the new cartridge is defective.
Ink Low Condition	--	--	Blink	 <p>Note : Printing operation can be performed until it becomes ink end condition even after the error message is displayed on STM3. However, the Head Cleaning operation may not be performed due to the Ink Low condition.</p>	<p>This error is detected when the ink consumption reaches about 90%.</p> <p>(Note) When the Ink Low Condition is detected, the Maintenance LED will blink. The printer will continue to keep this LED status even if a new Ink Cartridge is installed in the Ink Cartridge replacement position. However, this LED status will be reset (LED off) when "Carriage Unit" returns to the home position.</p>

Table 1-3. LED Indication and STM3



Printer status	LED indication			STM3 message	Condition for error detection
	Power	Paper	Ink		
Ink Out Error	--	--	On		<p>This error is detected in either of the following cases.</p> <ol style="list-style-type: none"> 1. The ink consumption reached 100%. 2. The Ink Cartridge is faulty. (CSIC memory data error) <p>(Note) If Ink Out Error is detected, a small amount of ink remains in the Ink Cartridge to protect the Print Head from printing operation.</p>
Paper Out Error	--	On	--		<p>This error is detected when the top of paper cannot be detected with the PE Sensor in a paper loading.</p>
Paper Jam Error (Including CD/DVD)	--	Blink	--		<p>This error is detected when ;</p> <ol style="list-style-type: none"> 1. The end of paper cannot be correctly detected with the PE Sensor in a paper loading. 2. The rear of CD/DVD cannot be correctly detected with the Star Wheel/CDR Sensor in a CD/DVD loading.

Table 1-3. LED Indication and STM3





Printer status	LED indication			STM3 message	Condition for error detection
	Power	Paper	Ink		
No Ink Cartridge	--	--	On		<p>This error is detected when ;</p> <ol style="list-style-type: none"> 1. The Ink Cartridge is not installed to "Carriage Unit". 2. The Ink Cartridge is defective.
Maintenance Request	Off	Alternant Blink 1	Alternant Blink 2		<p>This error is detected when the value of the Waste Ink Pad Counter A set in EEPROM reaches its limit (Variable between 20000 and 46750 points).</p>
CD/DVD Guide Error	--	Blink 2	Fast Blink		<p>This error is detected when ;</p> <ol style="list-style-type: none"> 1. Paper is present in "ASF Assy.," and "CDR Guide Assy." is open while receiving print data. 2. "CDR Guide Assy." opens while printing. 3. "CDR Guide Assy." is open while receiving ASF paper feed data. 4. Attempting to replace the ink while "CDR Guide Assy." is open.

Table 1-3. LED Indication and STM3

Printer status	LED indication			STM3 message	Condition for error detection
	Power	Paper	Ink		
CD/DVD Tray Error	--	On	--		This error is detected when "CD/DVD Tray" cannot be detected while CD/DVD printing.
Fatal error	Off	Fast Blink	Fast Blink		This error is detected when ; <ol style="list-style-type: none"> "Carriage Unit" cannot move correctly by the external force in each operation. "PF Motor" cannot rotate correctly while "PF Motor" operates.

Following is the Blink timing of each Blink condition.

- : No change of the LED status
- Blink : 0.5sec. on + 0.5sec. off
- Blink 2 : 0.2sec. on + 0.2sec. off + 0.2sec. on + 0.4sec. off
- Fast Blink : 0.1sec. on + 0.1sec. off
- Alternant Blink 1 : Same as Blink
- Alternant Blink 2 : Same as Blink

1.3 Unit Level Troubleshooting

You can identify the troubles by using the checklist in this section after confirming the LED/LCD indication on the control panel or the error message displayed on STM3 of the PC connected to the printer. As a result, you can save the whole repair time. When finding any faulty parts, refer to Chapter 2 "ASSEMBLY/DISASSEMBLY" and replace them. Following tables describe the error conditions (LED/LCD and STM3) and their possible cause.

The following is the example of how to use the tables.

Example) When "Carriage Unit" is out of the home position at the power on timing, the Fatal Error may be caused by the failure of "CR Motor". Moreover, there are 3 possible causes on "CR Motor" failure.

(Note)
When individual part that makes up "Roller EJ Assy.", "PF Motor" and "Ink System Assy." is defective, replace the Printer Mechanism with a new one basically. However, if an individual part needs to be replaced urgently, execute the necessary operation by referring to Chapter 2 "ASSEMBLY/DISASSEMBLY".

Table 1-4. Check Points for Communication Error to Each Phenomenon

Occurrence Timing Position of CR	Phenomenon Detail	Faulty Part/ Part Name	Check Point	Remedy
At power-on Anywhere	When turning on the power, the printer does not operate at all.	Power Supply Board	1. Check if "Power Supply Board Cable" is connected to the CN2 on "Main Board". 2. Check if "Power Supply Board Cable" is not damaged.	1. Connect "Power Supply Board cable" to the CN2 on "Main Board". 2. Replace "Power Supply Board" with a new one. * If the problem still occurs, replace "Main Board".
At operation	When turning on the power, the initialization is performed correctly. However, a Communication Error is displayed on STM3 even transferring the printing job to the printer.	Main Board	1. Check if the correct model name is written in EEPROM on "Main Board".	1. Write proper Market Setting in the Adjustment Program.
		USB Cable	1. Check if "USB Cable" is connected properly between the printer and the PC.	1. Connect the printer and the PC with a "USB Cable".
		Printer Driver	1. Check if the Stylus Photo R200/R210 Printer Driver is used for the printer job.	1. Install the Stylus Photo R200/R210 Printer Driver in the PC.

Table 1-5. Check Points for Error Before the Initial Ink Charge, Error Before Ink Cartridge Replacement Cleaning and No Ink Cartridge Error

Occurrence Timing Position of CR	Phenomenon Detail	Faulty Part/ Part Name	Check Point	Remedy
At power-on At HP	The printer does not perform the Initial Ink Charge and the error is displayed on LED and STM3.	Ink Cartridge	1. Check if the Ink Cartridge is normal by installing it in another printer.	1. Replace the Ink Cartridge with a new one.
		Main Board	1. Check if the correct data has been written in the address 5B<H> of EEPROM on "Main Board". (We cannot check it with Adjustment Program of Stylus Photo R200/R210.)	1. Write proper Market Setting in the Adjustment Program.
At power-on Anywhere	The printer does not perform the Ink Replacement Cleaning and the error is displayed on LED and STM3.	Ink Cartridge	1. Check if the Ink Cartridge is normal by installing it in another printer.	1. Replace the Ink Cartridge with a new one.
	The printer does not perform any print operation and the error is displayed on LED and STM3.	Ink Cartridge	1. Check if ink still remains in the Ink Cartridge. 2. Check if the Ink Cartridge is normal by installing it in another printer.	1. Replace the Ink Cartridge with a new one. 2. Replace the Ink Cartridge with a new one.

Table 1-6. Check Points for Paper Out Error to Each Phenomenon

Occurrence Timing Position of CR	Phenomenon Detail	Faulty Part/ Part Name	Check Point	Remedy
At operation	"Holder, Shaft, LD Roller" rotates to feed paper, but "Hopper" does not operate.	ASF Assy.	1. Check if "Hopper" works properly while feeding paper.	1. Reassemble "ASF Frame" and "Compression Spring, 2.51" correctly. 

Table 1-6. Check Points for Paper Out Error to Each Phenomenon

Occurrence Timing Position of CR	Phenomenon Detail	Faulty Part/ Part Name	Check Point	Remedy
At operation -	When feeding paper, the leading edge of paper is detected properly, but the paper is ejected without being set at the print start position.	ASF Assy.	1. Check if "Roller, Retard Assy." operates properly while feeding paper.	1. Reassemble "Extension Spring, 0.45" located the under side of "Roller, Retard Assy.". 
	"PF Motor" and "Spur Gear, 37.242" rotate properly, but "Holder, Shaft, LD Roller" does not feed paper. (The driving of "PF Motor" is not transmitted to "Holder, Shaft, LD Roller".)	Holder, Shaft, LD Roller	1. Check if "Extension Spring,0.143" in "Clutch Mechanism" has not come off. 2. Check if "Clutch" has not come off from the dowel of "Shaft, LD Roller". 3. Check if "Clutch Tooth" is not damaged.  4. Check if "Clutch" is not damaged.	1. Reassemble "Extension Spring, 0.143" in "Clutch Mechanism". 2. Reassemble the round portion of "Clutch" on the dowel of "Shaft, LD Roller". 3. Replace "Holder, Shaft, LD Roller" with a new one.
		Paper Guide, Upper (Only HP side)	1. Check if "Paper Guide, Upper" (only HP side) has not come off from "Main Frame".	1. Reassemble "Paper Guide, Upper" to "Main Frame".

Table 1-6. Check Points for Paper Out Error to Each Phenomenon

Occurrence Timing Position of CR	Phenomenon Detail	Faulty Part/ Part Name	Check Point	Remedy
At operation -	"PF Motor" and "Spur Gear, 37.242" rotate properly, but "Holder, Shaft, LD Roller" does not feed paper. (The drive of "PF Motor" does not propagate to "Holder, Shaft, LD Roller".)	Ink System	1. Check if "Compression Spring, 2.36" of "Lever, Change" does not come off. 	1. Replace "Ink System" with a new one.
	"Holder, Shaft, LD Roller" is not set in the ASF home position and paper is always fed from "ASF Assy".	Ink System	1. Check if the tip of "Lever, Change" is not damaged.	1. Replace "Ink System" with a new one.
	"Holder, Shaft, LD Roller" does not feed paper during the feeding operation. "PF Motor" and "Spur Gear, 37.242" also does not rotate at all.	PF Motor*	1. Check if "PF Connector Cable" is connected to CN6 on "Main Board". 2. Check if the coil resistance of "PF Motor" is approximately 3.0Ω with a tester. Refer to Table 1-1. 3. Check if "PF Motor Connector Cable" is damaged.	1. Connect "PF Motor Connector Cable" to CN6 on "Main Board". 2. Replace "PF Motor" with a new one. 3. Replace "PF Motor" with a new one.
At operation -	"Holder, Shaft, LD Roller" rotates properly, but paper is not fed.	Holder, Shaft LD Roller	1. Check if the surface of "LD Roller" is contaminated with paper dust. 	1. Remove the dust by using a soft brush or soft cloth moistened with alcohol. * If the problem is not solved, replace "LD Roller" with a new one.

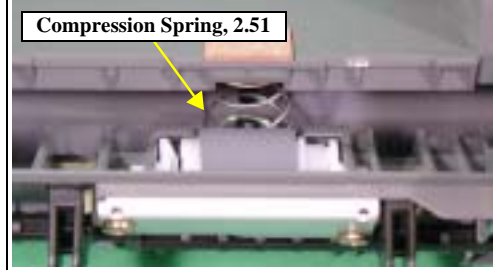
Table 1-7. Check Points for Paper Jam Error to Each Phenomenon

Occurrence Timing Position of CR	Phenomenon Detail	Faulty Part/ Part Name	Check Point	Remedy
At power-on Anywhere	"PF Motor" does not work at all.	PF Motor	<ol style="list-style-type: none"> 1. Check if "PF Motor Connector Cable" is connected to CN6 on "Main Board". 2. Check if the coil resistance of "PF Motor" is approximately 3.0Ω with a tester. Refer to Table 1-1. 3. Check if "PF Motor Connector Cable" is damaged. 	<ol style="list-style-type: none"> 1. Connect "PF Motor Connector Cable" to CN6 on "Main Board". 2. Replace "PF Motor" with a new one. 3. Replace "PF Motor" with a new one.
	Paper feeding operation is performed normally, but paper is not sent into the printer.	ASF Assy.	<ol style="list-style-type: none"> 1. Check if "Roller, Retard Assy." operates properly while feeding paper. 	<ol style="list-style-type: none"> 1. Reassemble "Extension Spring, 0.45" located the under side of "Roller, Retard Assy.". 
		PE Sensor	<ol style="list-style-type: none"> 1. Check if "Torsion Spring, 0.22" is not unfastened from "PE Sensor Lever".  <ol style="list-style-type: none"> 2. Check if "PE Sensor Cable" is not unfastened. 3. Check if "PE Sensor Cable" is correctly mounted on "Holder, Shaft, LD Roller". 4. Check if "PE Sensor Cable" is not damaged. 	<ol style="list-style-type: none"> 1. Reassemble "Torsion Spring, 0.22" 2. Connect "PE Sensor" Connector to CN9 on "Main Board". 3. Remount "PE Sensor Cable" correctly. 4. Replace "PE Sensor" with a new one.

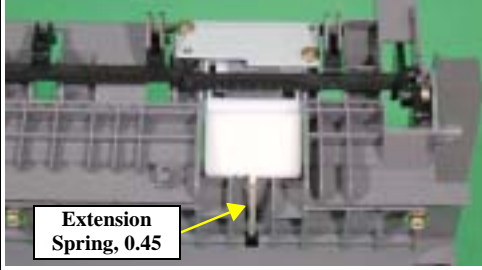
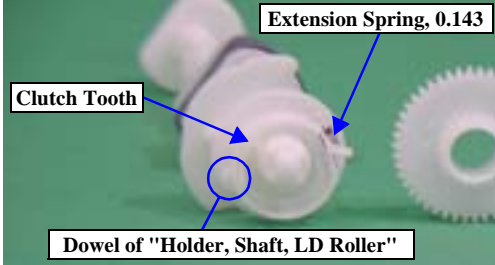
Table 1-7. Check Points for Paper Jam Error to Each Phenomenon

Occurrence Timing Position of CR	Phenomenon Detail	Faulty Part/ Part Name	Check Point	Remedy
At operation Out of HP	"Carriage Unit" moves to the home position properly when turning on the power. Then paper feeding operation is performed normally, but paper is not sent into the printer.	PE Sensor*	<ol style="list-style-type: none"> 1. Check if "Torsion Spring, 0.22" for "PE Sensor Lever" is not unfastened. 2. Check if "PE Sensor Cable" is correctly mounted on "Holder, Shaft, LD Roller". 	<ol style="list-style-type: none"> 1. Reassemble "Torsion Spring, 0.22". 2. Remount "PE Sensor Cable" correctly.
At operation -	When feeding paper, the leading edge of paper is detected properly, but the paper is ejected without being set at the print start position. At this time, the next paper is fed to "PE Sensor Lever".	ASF Assy.	<ol style="list-style-type: none"> 1. Check if "Roller, Retard Assy." operates properly while feeding paper. 	<ol style="list-style-type: none"> 1. Reassemble "Extension Spring, 0.45" back of "Roller, Retard Assy." 
	The leading edge of paper does not go through between "Roller EJ Assy." and "Star Wheels".	Frame EJ Assy.**	<ol style="list-style-type: none"> 1. Check if "Star Wheels" have not come off. 2. Check if "Frame EJ Assy." is correctly assembled. 3. Check if "Frame EJ Assy." is not transformed toward downward. 	<ol style="list-style-type: none"> 1. Reassemble "Star Wheels" correctly. 2. Reassemble "Frame EJ Assy." correctly. 3. Replace "Frame EJ Assy." with a new one.
		Paper Guide, Front	<ol style="list-style-type: none"> 1. Check if "porous pad" of "Paper Guide, Front" has not come off. 	<ol style="list-style-type: none"> 1. Remount "porous pad" correctly.
		Roller EJ Assy.	<ol style="list-style-type: none"> 1. Check if "Roller EJ Assy." is correctly assembled. 2. Check if "Spur Gear, 41.48" has not come off. 	<ol style="list-style-type: none"> 1. Reassemble "Roller EJ Assy." correctly onto "Printer Mechanism". 2. Reattach "Spur Gear, 41.48" to "Roller EJ Assy." correctly.

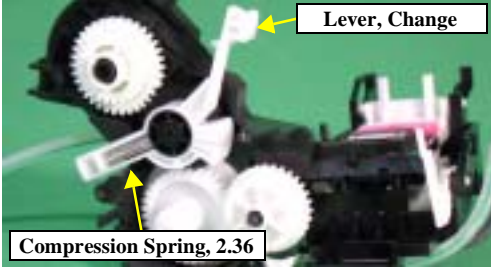
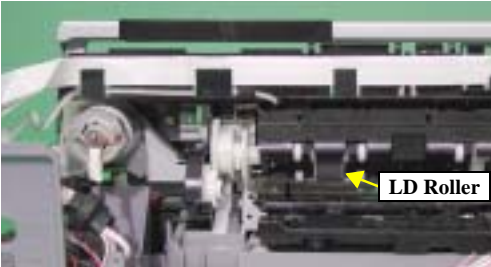
Table 1-7. Check Points for Paper Jam Error to Each Phenomenon

Occurrence Timing Position of CR	Phenomenon Detail	Faulty Part/ Part Name	Check Point	Remedy
At operation -	The leading edge of paper is not sent to "PF Roller".	Paper Guide, Upper	1. Check if "Paper Guide, Upper" has not come off from "Main Frame". 	1. Reattach "Paper Guide, Upper" to "Main Frame".

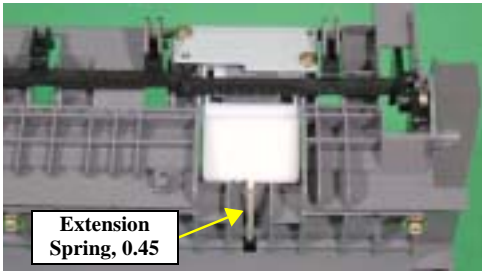
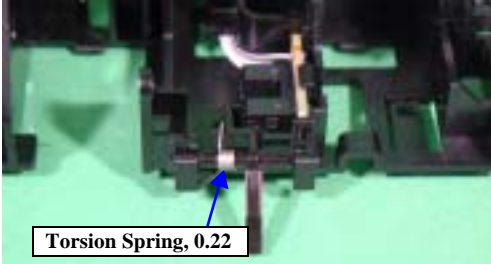
* "Carriage Unit" can move to the home position even if "Extension Spring, 0.22" has come off or "PE Sensor" is not set in the correct position. However, in the next operation, a Paper Jam Error will be detected since "PE Sensor Lever" will maintain the High signal status.

** There some cases where the jammed paper may damage "Print Head" by contacting the surface of "Print Head nozzle" when a Paper Jam Error occurs in each operation.

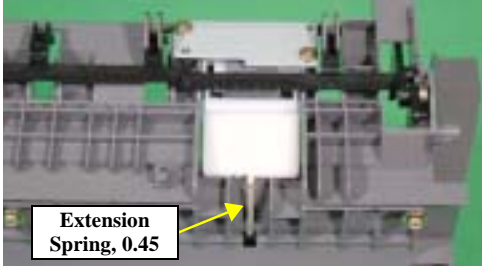
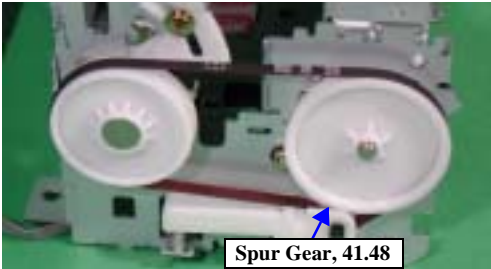
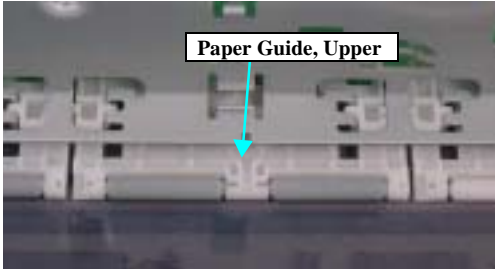
Table 1-8. Check Points for CD/DVD Guide Error to Each Phenomenon

Occurrence Timing Position of CR	Phenomenon Detail	Faulty Part/ Part Name	Check Point	Remedy
At power-on At HP	An error occurs even if "CDR Guide Assy." is closed when turning on the power.	Housing, Middle	1. Check if the contact point of "Housing, Middle" with "Star Wheel/CDR Sensor" is not cracked. 	1. Replace "Housing, Middle" with a new one.
		Star Wheel/ CDR Sensor	1. Check if "Star Wheel/CDR Sensor" is connected to CN11 on "Main Board".  2. Check if "Star Wheel/CDR Sensor" is not damaged. 3. Check if "Star Wheel/CDR Sensor" cable is not cut off.	1. Connect "Star Wheel/CDR Sensor" to CN11 on "Main Board". 2. Replace "Star Wheel/CDR Sensor" with a new one. 3. Replace "Star Wheel/CDR Sensor" with a new one.
		Main Board	1. Check if any device on "Main Board" is not damaged.	1. Replace "Main Board" with a new one.

Table 1-9. Check Points for CD/DVD Tray Error to Each Phenomenon

Occurrence Timing Position of CR	Phenomenon Detail	Faulty Part/ Part Name	Check Point	Remedy
When printing CDR/DVDR -	An error occurs even though "CDR Tray" is set when printing CDR/DVDR.	CDR Tray	1. Check if the contact point of "CDR Tray" with "CDR Tray Sensor" is not cracked. 	1. Replace "CDR Tray" with a new one.
		CDR Tray Sensor	1. Check if "CDR Tray Sensor" is connected to CN11 on "Main Board".  2. Check if "CDR Tray Sensor" is not damaged. 3. Check if "CDR Tray Sensor Connector Cable" is not cut off.	1. Connect "CDR Tray Sensor" to CN11 on "Main Board". 2. Replace "CDR Tray Sensor" with a new one. 3. Replace "CDR Tray Sensor" with a new one.
		Main Board	1. Check if any device on "Main Board" is not damaged.	1. Replace "Main Board" with a new one.

Table 1-10. Check Points for Fatal Error to Each Phenomenon

Occurrence Timing Position of CR	Phenomenon Detail	Faulty Part/ Part Name	Check Point	Remedy
At power-on Out of HP	"CR Motor" does not work at all when turning on the power.	CR Motor	1. Check if "CR Motor Connector Cable" is connected to CN5 on "Main Board". 2. Check if "CR Motor Connector Cable" is not damaged.	1. Connect "CR Motor Connector Cable" to CN5 on "Main Board". 2. Replace "CR Motor" with a new one.
		PF Motor	1. Check if "PF Motor Connector Cable" is connected to CN6 on "Main Board". 2. Check if the resistance of "PF Motor" is approximately 3.0Ω using a tester. Refer to Table 1-1. 3. Check if "PF Motor Connector Cable" is not damaged.	1. Connect "PF Motor Connector Cable" to CN6 on "Main Board". 2. Replace "PF Motor" with a new one. 3. Replace "PF Motor" with a new one.
	"Carriage Unit" strikes on "Lever, Change" which is leaning forward when turning on the power.	Ink System	1. Check if "Compression Spring, 2.36" of "Lever, Change" has not come off. 	1. Replace "Ink System" with a new one.
	"Carriage Unit" strikes on "Paper Guide, Upper" which has come off from "Main Frame" when turning on the power.	Paper Guide, Upper	1. Check if "Paper Guide, Upper" has not come off from "Main Frame". 	1. Reassemble "Paper Guide, Upper" to "Main Frame".
At power-on Anywhere	"Carriage Unit" strikes on the right side of "Main Frame" when turning on the power.	CR Scale	1. Check if "CR Scale" has not come off or it properly passes through the slit of "CR Encoder Sensor Board".	1. Reassemble "CR Scale" correctly. * If the problem is not solved, replace "Main Board" with a new one.

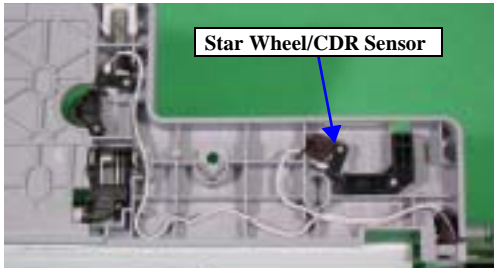
Table 1-11. Check Points When More Than One Paper is Fed Constantly Without LED/STM3's Error Notifications

Occurrence Timing Position of CR	Phenomenon Detail	Faulty Part/ Part Name	Check Point	Remedy
At operation -	The printer always feeds more than one sheet of paper without LED/STM3's error notifications.	ASF Assy.	1. Check if "Roller, Retard Assy." works correctly while feeding paper.	1. Reassemble "Extension Spring, 0.45" on the back of "Roller, Retard Assy." 

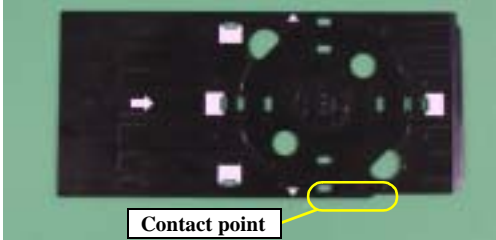
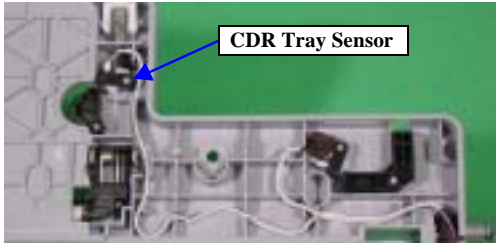
Table 1-12. Check Points for Abnormal Sound

Occurrence Timing Position of CR	Phenomenon Detail	Faulty Part/ Part Name	Check Point	Remedy
Any time Anywhere	Abnormal sound is heard in spite of the normal print operation at the first power on or some other time.	Carriage Unit	1. Check if there is enough grease on "CR Guide Shaft".	1. Wipe the remaining grease off "CR Guide Shaft" and reapply some grease.
		Ink System	1. Check if "Lever, Change" moves smoothly.	1. Replace "Ink System" with a new one.
	The bottom of "Carriage Unit" touches the surface of "Front Frame".	Frame EJ Assy.	1. Check if "Frame EJ Assy." is not warping upward.	1. Replace "Frame EJ Assy." with a new one.
	"Carriage Unit" strikes on "Paper Guide, Upper" while "Carriage Unit" is working.	Paper Guide, Upper	1. Check if "Paper Guide, Upper" has not come off from "Main Frame".	1. Reassemble "Paper Guide, Upper" to "Main Frame".

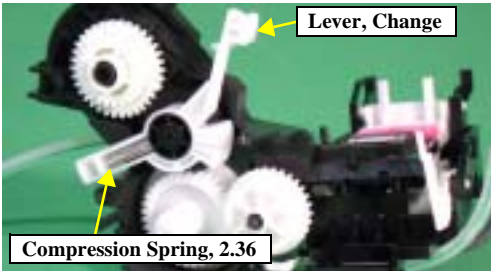
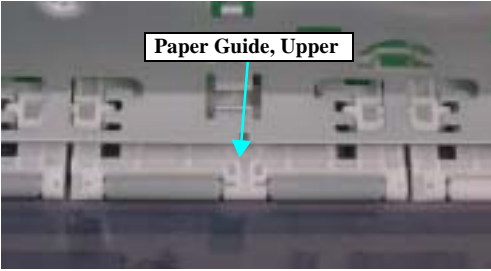
Table 1-13. Check Points for Defective Print Quality

Occurrence Timing Position of CR	Phenomenon Detail	Faulty Part/ Part Name	Check Point	Remedy
<p>At operation</p> <p>-</p>	<p>[Phenomenon 1] When the printer is performing the Cleaning task, the ink is not drained into "Waste Ink Pad" in spite of the correct function of "Pump Unit". The ink is not absorbed from "Print Head" to the Cap at all.</p> <p>[Phenomenon 2] When the printer is performing the Cleaning task, the ink is drained into "Waste Ink Pad". (This indicates that both of "Pump Unit" and "Cap Unit" are working correctly.) However, missing dots is not solved at certain nozzles even performing the Cleaning several times.</p> <p>[Phenomenon 3] When the printer is performing the Cleaning task, the ink is drained into "Waste Ink Pad". (This indicates that both of "Pump Unit" and "Cap Unit" work correctly.) However, the wiping function is not executed correctly and some different colors of ink mix together.</p> <p>[Phenomenon 4] When the printer is performing the Cleaning task, the ink is drained into "Waste Ink Pad". However, some missing dots occurs while printing.</p> <p>[Phenomenon 5] When the printer is performing the Cleaning task, the ink is drained into "Waste Ink Pad". However, missing dot occurs and the points where it occurs varies in every movement of the Cleaning.</p>	<p>Ink System</p>	<ol style="list-style-type: none"> 1. Check if there is not any foreign matter on the sealing rubber on "Cap Unit".  2. Check if the sealing rubber on "Cap Unit" is not damaged. 3. Check if "Compression Spring, 2.53" is properly attached in "Cap Unit".  4. Check if "Pump Tube" is properly connected to the bottom of "Cap Unit".  5. Check if "Extension Spring, 0.788" has not come off from "Slider Cap". 6. Check if "Extension Spring, 0.441" has not come off from "Slider Cap".  	<ol style="list-style-type: none"> 1. Remove the foreign matter from the sealing rubber. 2. Replace "Ink System" with a new one. 3. Replace "Ink System" with a new one. 4. Replace "Ink System" with a new one. 5. Reassemble "Extension Spring, 0.788" correctly. 6. Reassemble "Extension Spring, 0.441" correctly.

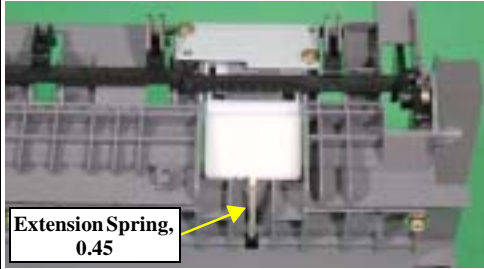
Table 1-13. Check Points for Defective Print Quality

Occurrence Timing Position of CR	Phenomenon Detail	Faulty Part/ Part Name	Check Point	Remedy
At operation -	<p>[Phenomenon 6] When the Cleaning is working, the ink is drained into "Waste Ink Pad". However, some missing dots and out of alignment occur while printing. They are not solved even executing the Cleaning several times.</p> <p>* If the problem is not solved, replace "Main Board" with a new one.</p>	Ink System	7. Check if "Slider Lock Lever" is not damaged.	7. Replace "Ink System" with a new one.
		Ink Cartridge	1. Check if ink still remains in Ink Cartridge	1. Replace the Ink Cartridge with a new one.
		Print Head	<ol style="list-style-type: none"> 1. Check if there is not any foreign matter on the nozzle surface of "Print Head". 2. Check if "Head FFC" is connected to CN7 and CN8 on "Main Board", or to the board on "Print Head". 3. Check if "Head FFC" is not damaged. 4. Check if each segment prints correctly with the Nozzle Check Pattern. 	<ol style="list-style-type: none"> 1. Perform the wiping operation. Replace "Wiper" when "Wiper" is deformed or contaminated awfully. 2. Securely connect "Head FFC" to "Main Board" or the board on "Print Head". 3. Replace "Head FFC" with a new one. 4. Perform Head Cleaning and check the Nozzle Check Pattern. <p>* If the problem is not solved, replace "Print Head" with a new one.</p>
	<p>Banding phenomenon occurs in a direction perpendicular to "Carriage Unit" movement getting uneven print density.</p> <div data-bbox="481 821 645 1034" style="text-align: center;"> </div> <p>(Note) If the problem is not solved, replace "CR Motor" with a new one.</p>	Carriage Unit	<ol style="list-style-type: none"> 1. Check if there is no foreign matter on the surface of "CR Guide Shaft". 2. Check if there is no damage on the surface of "CR Guide Shaft". 3. Check if there is enough grease on the surface of "CR Guide Shaft". 4. Check if "CR Guide Shaft" is properly connected to "Main Frame" with the fixing spring of "CR Guide Shaft". 	<ol style="list-style-type: none"> 1. Remove the foreign matter on "CR Guide Shaft". 2. Replace "CR Guide Shaft" with a new one. 3. Wipe the surface of "CR Guide Shaft" with a dry soft cloth, and then apply G-63 to it. Refer to Section 4.1.3. 4. Reassemble "CR Guide Shaft" correctly.

Table 1-13. Check Points for Defective Print Quality

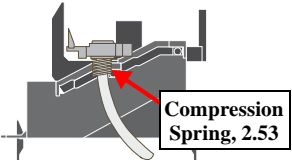
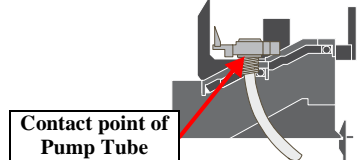
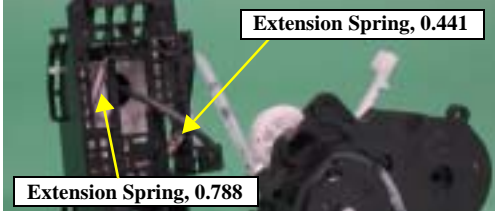

Occurrence Timing Position of CR	Phenomenon Detail	Faulty Part/ Part Name	Check Point	Remedy
At operation	Banding phenomenon occurs in a direction perpendicular to "Carriage Unit" movement getting uneven print density.	Frame EJ Assy.	1. Check if the surface of "Frame EJ Assy." is precisely horizontal.	1. Replace "Frame EJ Assy." with a new one.
		Print Head	1. Check if "Print Head" prints correctly with the Nozzle Check Pattern.	1. Perform the Head Cleaning, then check the Nozzle Check Pattern. * If the problem is not solved, replace "Print Head" with a new one.
	Banding phenomenon occurs in a direction horizontally to "Carriage Unit" movement.	PF Roller	1. Check if there is not any foreign matter on the surface of "PF Roller". 2. Check if "PF Roller" is not damaged. 3. Check if "Spur Gear, 37.242" is not damaged or broken.	1. Clean the surface of "PF Roller". 2. Replace "Printer Mechanism" with a new one. 3. Replace "Printer Mechanism" with a new one.
		Printer Driver and Special Paper	1. Check if appropriate paper is used in accordance with the Printer Driver settings.	1. Use the appropriate type of paper in accordance with the Printer Driver.
	(Note) If the problem is not solved, replace "PF Motor" with a new one.	Print Head	1. Check if "Print Head" prints correctly with the Nozzle Check Pattern.	1. Perform the Head Cleaning, then check the Nozzle Check Pattern. * If the problem is not solved, replace "Print Head" with a new one.
Banded stripes appear in a direction horizontally to "Carriage Unit" movement.	Paper Guide, Front	1. Check if "porous pad" in front of "Paper Guide, Front" has not come off.	1. Reattach "porous pad".	
				These stripes appear when the print paths overlap each other.

Table 1-13. Check Points for Defective Print Quality

Occurrence Timing Position of CR	Phenomenon Detail	Faulty Part/ Part Name	Check Point	Remedy
At operation -	One or more than one traces of "Star Wheels" appear in a direction perpendicular to "Carriage Unit" movement. 	Frame EJ Assy.	1. Check if "Star Wheels" have not come off. 2. Check if the surface of "Frame EJ Assy." is mounted horizontally.	1. Reassemble "Star Wheels" correctly. 2. Replace "Frame EJ Assy." with a new one.
		Roller EJ Assy.	1. Check if "Roller EJ Assy." has not come off from "Printer Mechanism".	1. Reassemble "Roller EJ Assy." correctly.
	Normal printing task is performed; however, the top margin is less than usual.	Holder, Shaft, LD Roller	1. Check if any paper dust has not adhered to the surface of "LD Roller". 	1. Remove the dust by using a soft brush or soft cloth moistened with alcohol. * If the problem is not solved, replace "Holder, Shaft, LD Roller" with a new one.
	The print is light and thin.	Printer Driver and Special Paper	1. Check if appropriate paper is used in accordance with the Printer Driver settings.	1. Use the appropriate type of paper in accordance with the Printer Driver settings.
		Print Head	1. Check if the correct Head ID has been input in EEPROM by using the Adjustment Program.	1. Input 15-digit ID code of the Head ID in EEPROM by using the Adjustment Program

Table 1-13. Check Points for Defective Print Quality

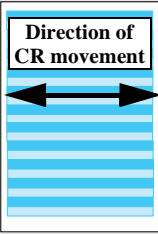
Occurrence Timing Position of CR	Phenomenon Detail	Faulty Part/ Part Name	Check Point	Remedy
At operation -	The paper is stained with the ink.	Frame EJ Assy.	1. Check if there is any ink adhesion on "Frame EJ Assy.".	1. Clean the ink adhesion on "Frame EJ Assy." with a soft cloth.
			1. Check if "Frame EJ Assy." has not warped upward.	1. Replace "Frame EJ Assy." with a new one.
		Paper Guide, Front	1. Check if there is any ink adhesion on "Paper Guide, Front". 2. Check if "porous pad" of "Paper Guide, Front" has not come off.	1. Clean the ink adhesion on "Paper Guide, Front" with a soft cloth. 2. Reattach "porous pad".
		Roller EJ Assy.	1. Check if there is any ink adhesion on "Roller EJ Assy.".	1. Clean the ink adhesion on "Roller EJ Assy." with a soft cloth.
		Paper Guide, Upper	1. Check if there is any ink adhesion on "Paper Guide, Upper".	1. Clean the ink adhesion on "Paper Guide, Upper" with a soft cloth.
		PF Roller	1. Check if there is any ink adhesion on "PF Roller".	1. Clean the ink adhesion on "PF Roller" with a soft cloth.
		Ink System	1. Check if the wiping operation has been performed correctly.	1. Replace "Ink System" with a new one.
Print Head	1. Check if there is any ink adhesion on "Print Head Cover".	1. Clean the ink adhesion on "Print Head Cover" with a soft cloth.		
	The upper edge of the paper gets creased.	ASF Assy.	1. Check if "Hopper Pad" is stuck to "Hopper" correctly.	1. Replace "ASF Assy." with a new one.

CHAPTER

2

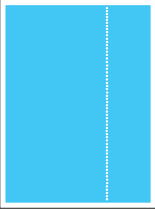
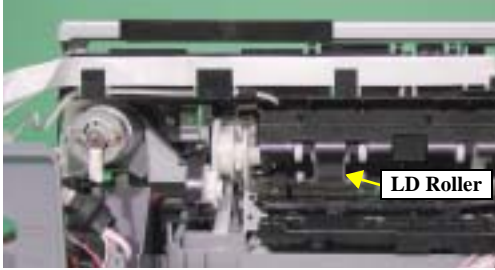
DISASSEMBLY AND ASSEMBLY

2.1 Overview

This section describes procedures for disassembling the main components of Stylus Photo R200/R210. Unless otherwise specified, disassembly units or components can be reassembled by reversing the disassembly procedure.

"WARNING" indicates procedures which may result in damage, injury or involving human lives if you don't take extra care.

"CAUTION" indicates precautions for any disassembly or assembly procedures.

"CHECK POINT" indicates points to be checked.

"REASSEMBLY" indicates reassembling procedures which are different from the reverse order of the disassembling.

"ADJUSTMENT REQUIRED" indicates required adjustments after the assembly and the disassembly.

Read precautions described in the next section before starting.

2.1.1 Precautions

Before starting the disassembling/reassembling work of this product, always read the descriptions under the following headings "WARNING" and "CAUTION" carefully.



- **Disconnect the power cable before disassembling or assembling the printer.**
- **If you need to work on the printer with power applied, strictly follow the instructions in this manual.**
- **Wear protective goggles to protect your eyes from ink. If ink gets in your eye, flush the eye with fresh water and see a doctor immediately.**
- **Always wear gloves for disassembly and reassembly to avoid injury from sharp metal edges.**
- **To protect sensitive microprocessors and circuitry, use static discharge equipment, such as anti-static wrist straps, when accessing internal components.**
- **Never touch the ink or wasted ink with bare hands. If ink comes into contact with your skin, wash it off with soap and water immediately. If you have a skin irritation, consult a physician.**
- **When reassembling the waste ink pads and tray, always make sure that the waste ink tube is fitted correctly in the specified place. Fitting the ink tube in other than the specified position can cause ink leakage.**



- **Avant de commencer, assure vous que l'imprimante soit éteinte et que le cordon d'alimentation soit débranché.**
- **Veillez à jeter les piles usagées selon le règlement local.**



- **Risque d'explosion si la pile est remplacée incorrectement. Ne remplacer que par une pile du même type ou d'un type équivalent recommandé par le fabricant. Éliminer les piles déchargées selon les lois et les règles de sécurité en vigueur.**



- **When transporting the printer after installing the ink cartridge, be sure to pack the printer for transportation without removing the ink cartridge.**
- **Use only recommended tools for disassembling, assembling or adjusting the printer. (Refer to Table 2-1 "Tool List".)**
- **Observe the specified torque when tightening screws.**
- **Use the specified lubricants and adhesives. (Refer to Chapter 4 for details.)**
- **Make the specified adjustments when you disassemble the printer. (Refer to Chapter 3 for details.)**

2.1.2 Tools

Use only specified tools to avoid damaging the printer.

Table 2-1. Tools

Tool Name	Supplier	Code
Phillips Screw Driver (No. 0)	EPSON	1080531
Phillips Screw Driver (No. 1)	EPSON	1080530
Phillips Screw Driver (No. 2)	EPSON	1080532
Tweezers	EPSON	1080561
Acetate Tape	EPSON	1003963

2.1.3 Pre-shipment Checks

When returning this product to the user after completing printer repair, check that the work is complete using the following table.

Table 2-2. Service Completion Pre-shipment Check List

Classification	Item	Check Point	Status
Main Unit	Self-test	Is the operation normal?	<input type="checkbox"/> Checked <input type="checkbox"/> Not necessary
	On-line Test	Is the printing successful?	<input type="checkbox"/> Checked <input type="checkbox"/> Not necessary
	Print Head	Is ink discharged normally from all the nozzles?	<input type="checkbox"/> Checked <input type="checkbox"/> Not necessary
	Carriage Mechanism	Does it move smoothly?	<input type="checkbox"/> Checked <input type="checkbox"/> Not necessary
		Is there any abnormal noise during its operation?	<input type="checkbox"/> Checked <input type="checkbox"/> Not necessary
		Is there any dirt or foreign objects on the CR Guide Shaft?	<input type="checkbox"/> Checked <input type="checkbox"/> Not necessary
		Is the CR Motor at the correct temperature? (Not too heated?)	<input type="checkbox"/> Checked <input type="checkbox"/> Not necessary
	Paper Feeding Mechanism	<ul style="list-style-type: none"> • Is paper fed smoothly? • No paper jamming? • No paper skew? • No multiple feeding? • No abnormal noise? 	<input type="checkbox"/> Checked <input type="checkbox"/> Not necessary
		Is the PF Motor at correct temperature?	<input type="checkbox"/> Checked <input type="checkbox"/> Not necessary
		Is the paper path free of any obstructions?	<input type="checkbox"/> Checked <input type="checkbox"/> Not necessary
	Adjustment	Specified Adjustment	Are all the adjustment done correctly?

Table 2-2. Service Completion Pre-Shipment Check List

Classification	Item	Check Point	Status
Lubrication	Specified Lubrication	Are all the lubrication made at the specified points?	<input type="checkbox"/> Checked <input type="checkbox"/> Not necessary
		Is the amount of lubrication correct?	<input type="checkbox"/> Checked <input type="checkbox"/> Not necessary
Function	ROM Version	Is it the latest version? Version:	<input type="checkbox"/> Checked <input type="checkbox"/> Not necessary
Packing	Ink Cartridge	Are the ink cartridges installed correctly?	<input type="checkbox"/> Checked <input type="checkbox"/> Not necessary
	Protective Materials	Have all relevant protective materials been attached to the printer?	<input type="checkbox"/> Checked <input type="checkbox"/> Not necessary
Others	Attachments, Accessories	Have all of the accessories been included in the package?	<input type="checkbox"/> Checked <input type="checkbox"/> Not necessary

2.2 Caution regarding assembling/disassembling the printer mechanism, and how to ensure the quality of reassembled product

For the existing Low End models, it is basically forbidden to remove "Housing, Lower" from "Printer Mechanism". This is because the strength of "Frame, Main" is not strong enough, therefore, "Frame, Main" may be transformed when removing/reinstalling it from/to "Housing, Lower".

For that reason, when replacing "Ink System" or "PF Motor", it is recommended to replace not only "Housing, Lower" but also "Printer Mechanism".

For this printer, it is necessary that "Housing, Lower" be removed from "Printer Mechanism" when replacing "Waste ink Pads" or "Ink System Unit".

Therefore, this chapter specifies the disassembly/assembly of "Printer Mechanism" which "Housing, Lower" has been taken out in order to secure the quality of the repaired items.

□ Caution for disassembly/assembly of Printer Mechanism

1. "Printer Mechanism" with "Housing, Lower"
 - Do not hold "Guide Plate, CR" ⇒ Transforming of "Frame, Main" and "Guide Plate, CR" may give some bad influence to PG or printing.
 - Do not touch "CR Guide Shaft" and/or the surface of the head nozzle.
2. "Printer Mechanism" without "Housing, Lower"
 - Manage the standard values for installation. (See below)
 - First, remove "Support Plate, Frame, Main". Then, remove "Roller PF Unit", "Roller EJ Assy." and "Paper Guide, Front".
 - Make sure to manage "Waste Ink Tube".
 - Be careful with the interconnection of "Star Wheel/CDR Sensor" connector cable.
 - Assemble "Cam, CR, Left" while gearing with the APG gear.

■ Management of the reference position for installation

[Reason]

Accurate installation for each component of "Printer Mechanism" is on a basis of "Housing, Lower".

[Support for Service]

Check if there is no gap between "Frame, Main" and "Housing, Lower".

[Reference]

In order to ensure the accuracy for installation, it is necessary to manage the reference position for installation in X, Y and Z direction.

[X-axis direction]

- Check if "Frame, Main" is correctly set to the groove of "Housing, Lower".
- Check if there is no gap between "Frame, Main" and "Housing, Lower".

[Y-axis direction]

- Check if the slot of "Frame, Main" is correctly attached to the projection of "Housing, Lower".

[Z-axis direction]

- Check if there is no gap between "Frame, Main" and "Housing, Lower".
- Check if correctly secured with the hooks (2 on the left, 1 on the right, 1 on the right front) of "Printer Mechanism".

■ Management of the perpendicular accuracy of "Guide Plate, CR" (The standards of the guide rail's perpendicular direction is on the basis of the hooks of "Carriage Unit" and "Print Head".)

[Reason]

Deformation of "Guide Plate, CR" may cause the defective print/operation.

[Support for Service]

Specify the correct raising position for "Main Frame" so that it will not be deformed.

- How to install "ASF Unit", "Main Board" and "Paper Guide, Upper"

[Reason]

When installing these three components, too much force can be given to "Frame, Main", therefore, it may be deformed and cause the defective print/operation.

[Support for Service]

Hold the opposite side of the components securely, when installing them.

3. CDR Guide Assy.

- Management of the level accuracy of "CDR Guide Assy."

[Reason]

Deformation of "CDR Guide Assy." may cause the defective print.

[Support for Service]

Disassemble/assemble carefully "CDR Guide Assy.".

□ How to secure the quality for reassembled products

It can be judged that the quality for the reassembled products is guaranteed if the printing test with the Adjustment program is successful.

2.3 Disassembly

The following flowchart shows the order of disassembling procedure. When disassembling any unit, refer to the page number shown in the flowchart.

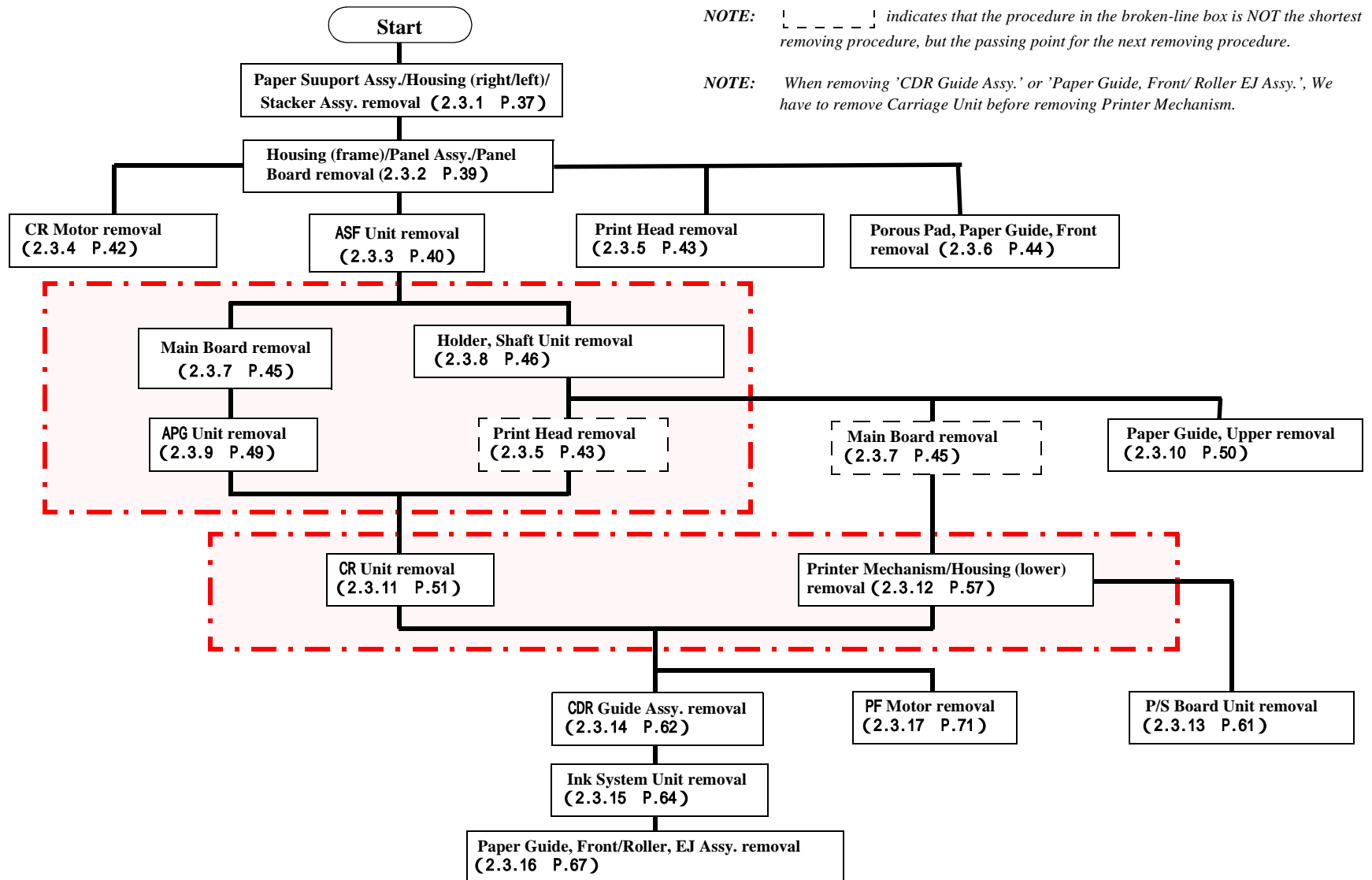

Figure 2-1. Disassembly Procedure Flowchart

2.3.1 Paper Support Assy./Housing (left/right)/Stacker Assy. removal

External View

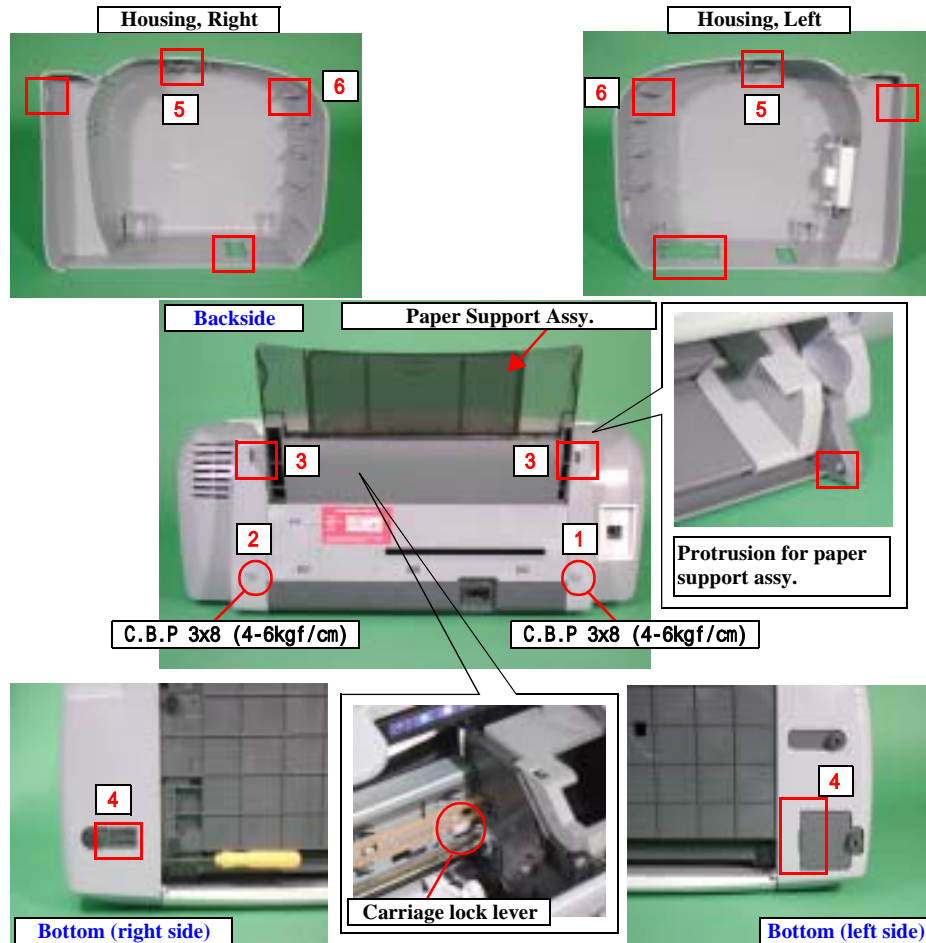

Figure 2-2. paper support assy./Housing (left/right)/Stacker assy. removal

- Parts/Units which should be removed before removing paper support assy./Housing (left/right)/Stacker assy.

Non

Disassembly Procedure

■ Paper support assy. removal

1. Release two protrusions for securing the paper support assy. to ASF frame.

■ Housing (left/right) removal

1. Remove the screw (1, x1, 2, x1) for securing the housing (left/right).
2. Release the hook (3, x1) forward by using screwdriver.
3. Release the hook (4, x1) by inserting minus screwdriver between the housing (lower) and the housing (left/right).
4. Release "Carriage Lock" with the tweezers or alike, then move "Carriage unit" to the centre of the printer.
5. Remove the housing (left/right) by insert your hand to the printer mechanism.

□ External View

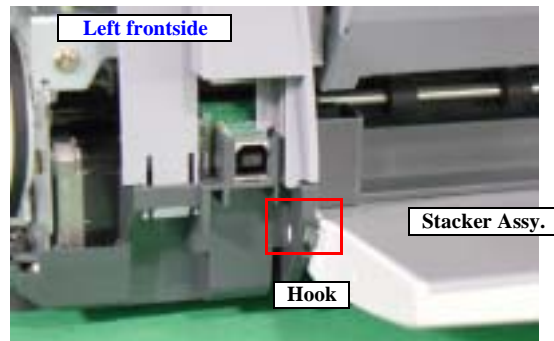

Figure 2-3. Stacker assy. removal

■ Stacker assy. removal

1. Release one hook for securing the stacker assy. to housing (lower), and remove it forward.



- When removing paper support assy./housing (left/right)/stacker assy.;
- Do not injure your hand by the tool, such as the screwdriver.
 - Do not tilt the printer too much because ink may flow if the cap is not covered by the print head.



- When reinstalling paper support assy./housing (left/right)/stacker assy.;
- Make sure that there is no clearance between the housing (left/right) and the housing (frame).
 - Make sure that the right side of the stacker assy. is set to the damper correctly.
 - Make sure that the paper support assy. is installed to the ASF unit.

2.3.2 Housing (frame)/Panel Assy./Panel Board removal

□ External View

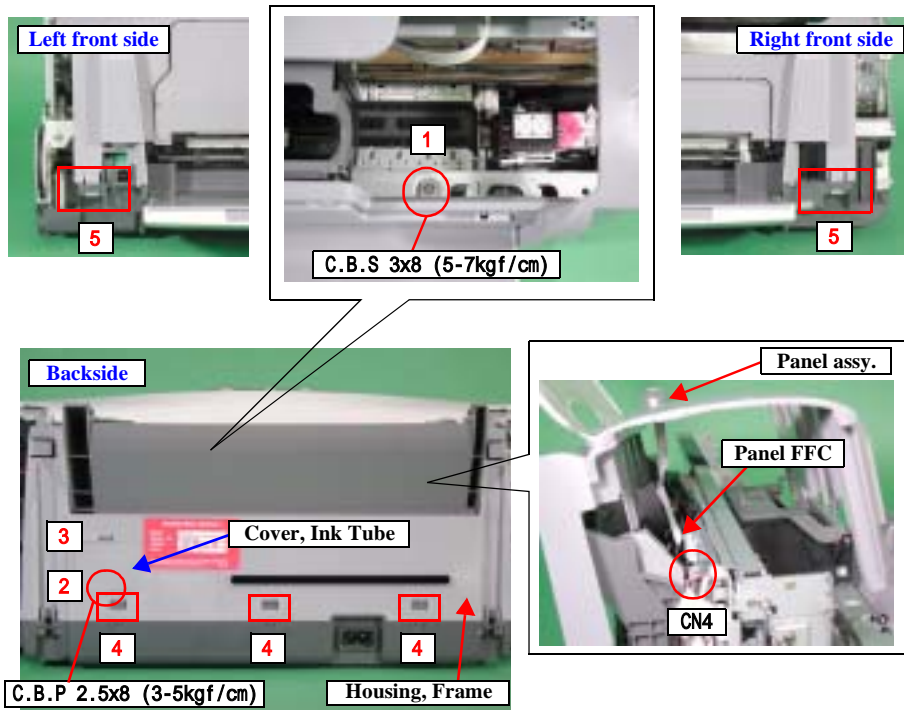

Figure 2-4. Housing (frame) removal

□ Parts/Units which should be removed before removing Housing (frame)/ Panel Assy./Panel board

Paper Support Assy./Housing (left/right)/Stacker Assy.

□ Disassembly Procedure

■ Housing (frame) removal

1. Remove the screw (1, x1) for securing the housing (frame) to the printer mechanism.
2. Remove the screw (2, x1) for securing the "Cover, Ink tube" to the housing (frame), and release the hook (3, x1) of the cover.
3. Release the hooks (4, x3) for securing the backside of the housing (frame).
4. Release the hooks (5, x2) for securing the front side of the housing (frame).
5. Remove the housing (frame) upward.

■ Panel Assy. removal

1. Release two hooks for securing the panel Assy. to the housing (frame).

■ Panel board removal

1. Remove the panel board upward.



□ When reinstalling the housing (frame),

- You have to reeve the panel FFC to the hole of the housing (frame) is inserted to the panel board before installing the housing (frame).
- Make sure to connect panel FFC to the main board (CN4)/ panel board before installing the housing (frame).

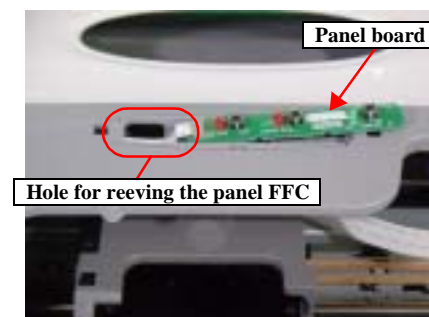

Figure 2-5. Panel board installation

- Make sure that there is no clearance between the housing (frame) and the housing (lower).

2.3.3 ASF Unit removal

□ External View

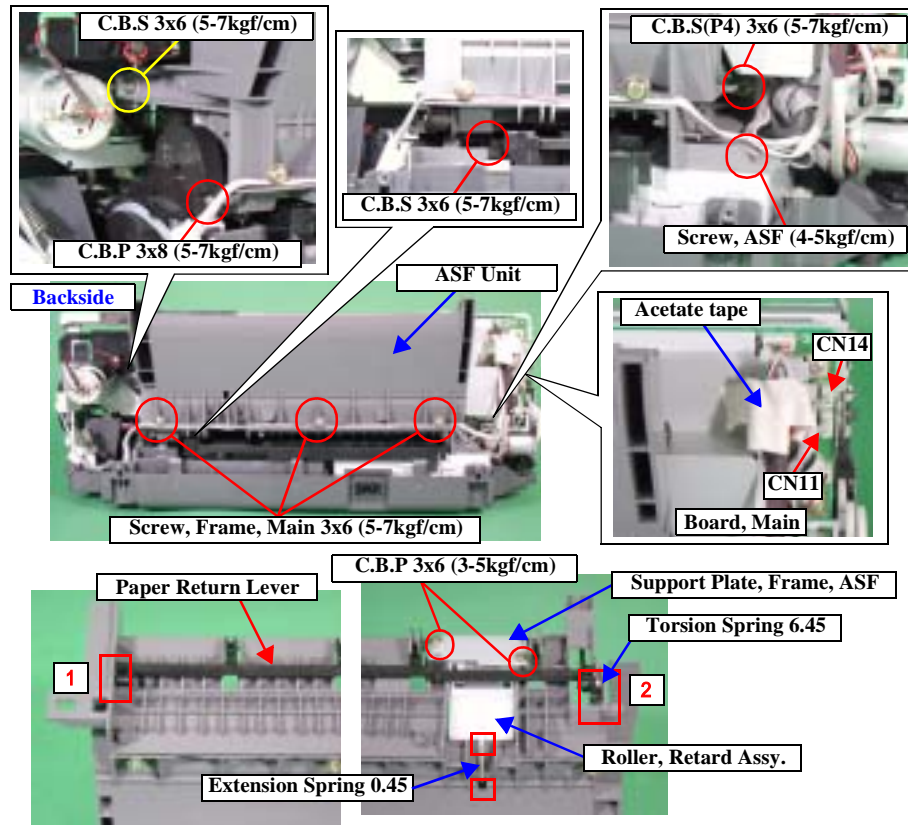

Figure 2-6. ASF Unit removal

□ Parts/Units which should be removed before removing "ASF Unit"

Paper Support Assy./Housing (left/right)/Housing (frame)

□ Disassembly Procedure

1. Disconnect the PG sensor connector cable & the CDR tray sensor cable from the connector (CN14/CN11) of the "Board, Main".
2. Remove the screws (x5) for securing "ASF Unit", and remove "ASF Unit" to the backside of the printer.
3. Remove the screws (x3) for securing the PG sensor connector cable & the CDR tray sensor cable to ASF frame, and release the cables.
4. Remove the ASF unit backward.
5. Open "Hopper" and then remove "Compression Spring, 2.51".
6. Bow slightly down "Paper Return Lever" and release the dowels (x2) on the both sides in the order of ①, ②., and remove "Paper Return Lever".



When removing "Paper Return Lever", the spring washer will detach and drop. Take care not to lose it.

7. Remove the screws (x2) for securing "Support Plate, Frame, ASF".
8. Release the hooks (x2) for securing "Extension Spring, 0.45", and remove "Roller, Retard Assy.".



- When reassembling "ASF Unit",
 - Make sure that "Extension Spring, 0.45" is hooked on "Frame, ASF" and "Roller, Retard Assy."
 - Make sure that "Torsion Spring, 6.45" is correctly installed on "Paper Return Lever" and "Frame, ASF".

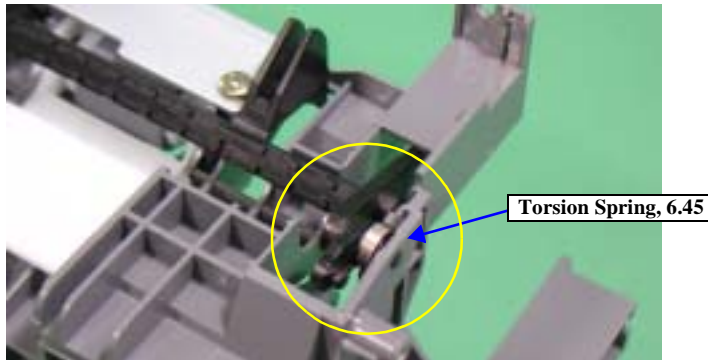

Figure 2-7. "Torsion Spring, 6.45" removal

- Make sure that "Paper Return Lever" and "Roller, Retard Assy." move smoothly.
- Do not touch the cork of "Hopper".



- When reinstalling "ASF Unit",
 - Install "Compression Spring, 2.51" on "Hopper", then check if "Hopper" moves smoothly.
 - Screw in the order as shown in the figure.
 - Make sure that there is no gap between "ASF Unit" and "Frame, Main".



- When having replaced "ASF Unit", apply G-46 grease to the specified points in adequate dose. (Refer to Chapter 4 "MAINTENANCE")
- When having replaced or removed "ASF Unit", implement the adjustment in the following order. (Refer to Chapter 3 "ADJUSTMENT")
 1. First Dot Adjustment

2.3.4 CR Motor removal

External View

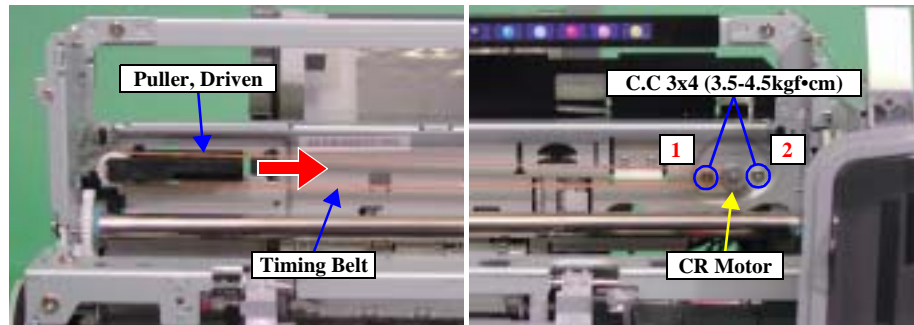
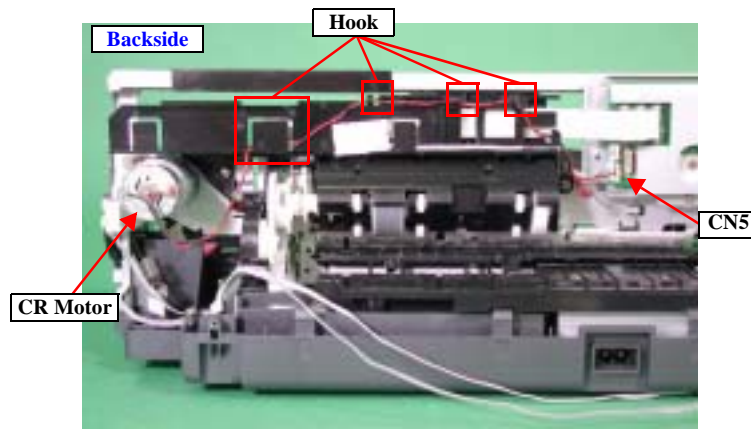

Figure 2-8. CR Motor removal

Parts/Units which should be removed before removing "CR Motor"

Paper Support Assy./Housing (left/right)/Housing (frame)

Disassembly Procedure

1. Disconnect the CR motor connector cable from the connector (CN5) of "Board, Main".
2. Release the CR motor connector cable from the "Holder, Shaft Unit".
3. Release the carriage lock with the tweezers or alike, then move "Carriage Unit" to the centre of the printer.
4. Push "Pulley, Driven" in the direction of the arrow and loosen the tension of "Timing Belt". Then, remove "Timing Belt" from the pinion gear of "CR Motor".
5. Remove the screws (x2) which secure "CR Motor", and remove "CR Motor".



Do not damage the pinion gear when removing "CR Motor".



When reinstalling the "CR Motor",

- Make sure to screw "CR Motor" in the order as shown in the figure.
- Make sure that there is no gap between "CR Motor" and "Frame, Main".
- Make sure that the part on which "CR Motor" Lot number is printed is face-up.



When having removed or replaced "CR Motor", implement the adjustment in the following order. (Refer to Chapter 3 "ADJUSTMENT")

1. First dot Adjustment
2. PW Sensor Adjustment
3. Head Angular Adjustment
4. Bi-D Adjustment
5. Offset Input for CR Motor Calorific Limitation (When Replaced)

2.3.5 Print Head removal

□ External View

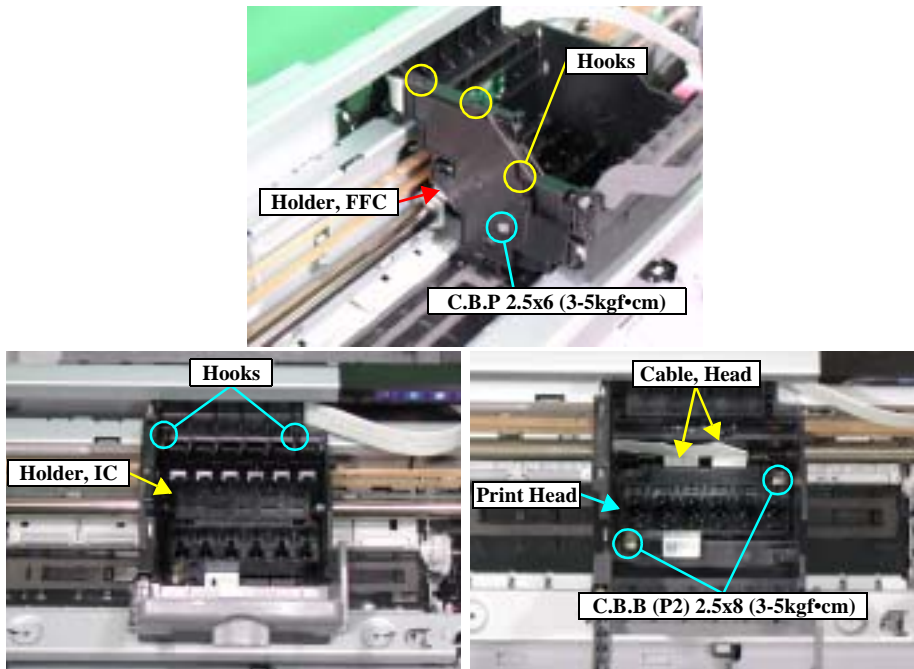

Figure 2-9. Print Head removal

□ Parts/Units which should be removed before removing "Print Head".

Paper Support Assy./Housing (left/right)/Housing (frame)

□ Disassembly Procedure

1. Remove all the ink cartridges from "Carriage Unit".
2. Release "Carriage Lock Lever" with the tweezers or alike, then move "Carriage Unit" to the centre of the printer.
3. Remove the screw (x1) for securing "Holder, FFC" with the No. 1 driver.
4. Slightly inflect the lower part of "Holder, FFC", release the hooks (x3) by sliding it downward. Then, remove "Holder, FFC".
5. Release the hooks (x2) for securing "Holder, IC", and remove "Holder, IC" upward.

6. Remove the screws (x2) for securing "Print Head" with Phillips screwdriver (No.1).
7. Disconnect "Cable, Head" from the connector (CN7/8) of "Print Head" while slightly lifting "Print Head", and remove "Print Head".



Do not touch and/or damage the nozzle surface of "Print Head" when handling it.



□ When reinstalling the "Print Head",

- Make sure that "Head FFC" is correctly connected to the connector (CN7/8) of "Print Head".
- Make sure that "Print Head" is correctly set to "Carriage Unit".
- Do not touch the nozzle surface of "Print Head".



□ When having removed or replaced "Print Head", implement the adjustment in the following order. (Refer to Chapter 3 "ADJUSTMENT")

1. Ink Charge (When Replaced)
2. Head ID Input (When Replaced)
3. PG Adjustment
4. First Dot Adjustment
5. PW Sensor Adjustment
6. Head Angular Adjustment
7. Bi-D Adjustment

2.3.6 Porous Pad, Paper Guide, Front removal

External View

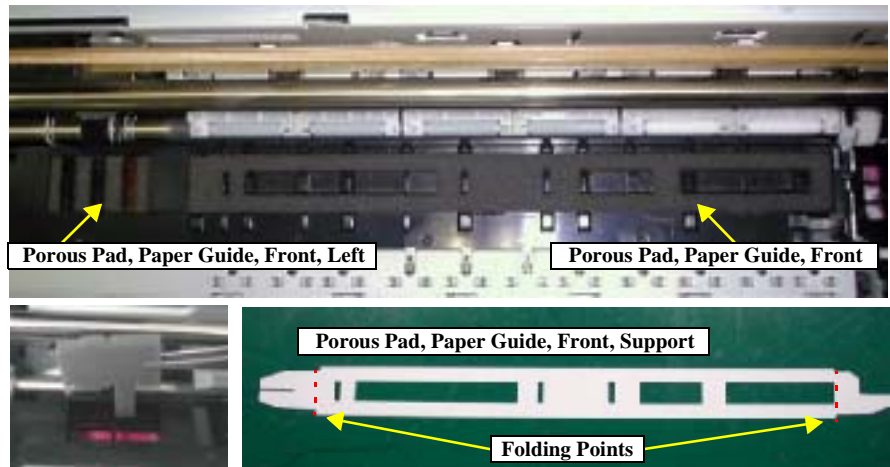

Figure 2-10. "Porous Pad, Paper Guide, Front" removal

Pars/Units which should be removed before removing "Porous Pad, Paper Guide, Front"

Paper Support Assy./Housing (left/right)/Housing (frame)

Disassembly Procedure

1. Remove the following 3 types of porous pads from "Paper Guide, Front" by using the tweezers.
 - Porous Pad, Paper Guide, Front
 - Porous Pad, Paper Guide, Front, Support
 - Porous Pad, Paper Guide, Front, Left



Make sure to take "Porous Pad, Paper Guide, Front" cleanly as it is glued.

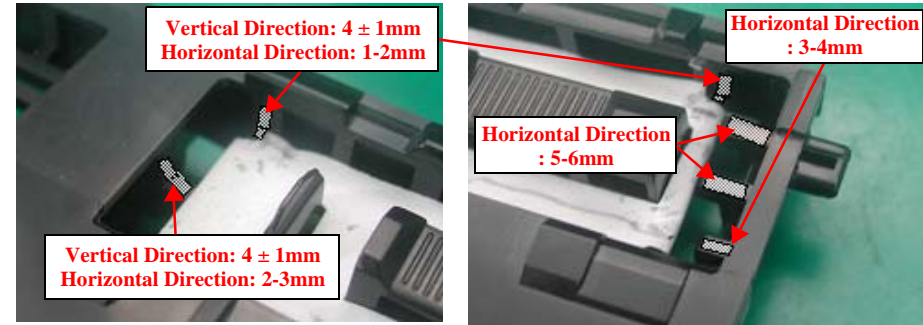

Figure 2-11. Gluing Point of "Porous Pad, Paper Guide, Front"



When reinstalling "Porous Pad, Paper Guide, Front"/"Porous Pad, Paper Guide, Front, Support"

- Fold perpendicularly left and right sides of "Porous Pad, Paper Guide, Front, Support" at the marks and install it to "Paper Guide, Front". Make sure that the slit engages with the rib located on the side of "Paper Guide, Front" so that they will fit securely.
- Apply ThreeBond 1401 to the 6 points shown in the figure above.
- Install "Porous Pad, Paper Guide, Front" in piles. Put it under the rib, and check if it is securely fit. Adjust the clearance between "Porous Pad, Paper Guide, Front" and "Paper Guide, Front" approximately in 0.5 - 1.0mm.

When reinstalling "Porous Pad, Paper Guide, Front, Support"

- Insert the foot-parts into the holes of "Paper Guide, Front". Then, put them under the rib and check if it is securely fit.



- Do not damage "Porous Pad, Paper Guide, Front, Support".
- Do not apply too much adhesive when using some. Do not contaminate "Porous Pad, Paper Guide, Front, Support" with the adhesive.
- Install "Porous Pad, Paper Guide, Front" immediately after applying the adhesive.
- Make sure that the 3 porous pads are fit securely.

2.3.7 Board, Main removal

□ External View

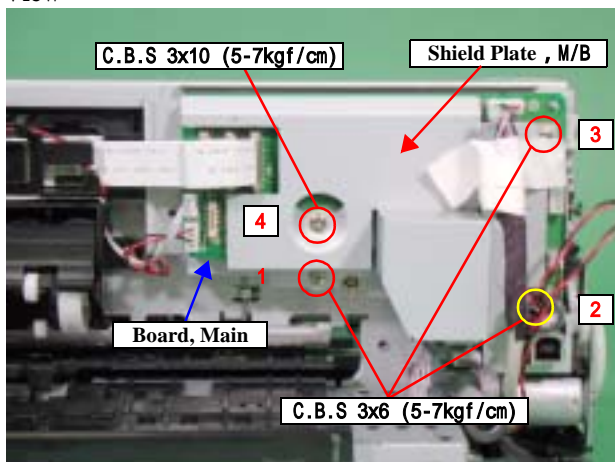

Figure 2-12. Board, Main removal

□ Pars/Units which should be removed before removing "Board, Main"

Paper Support Assy./Housing (left/right)/Housing (frame)/ASF Unit

□ Disassembly Procedure

- Disconnect all connector cables from "Board, Main".
 - CN2 : Power supply connector cable
 - CN4 : Panel board connector cable
 - CN5 : CR motor connector cable
 - CN6 : PF motor connector cable
 - CN7 : Head FFC
 - CN8 : Head FFC
 - CN9 : PE sensor connector cable
 - CN10 : Interface board connector cable
 - CN11 : CDR tray sensor cable
 - CN13 : APG motor connector cable
 - CN14 : PG sensor cable
 - CN15 : CSIC/CR encoder /PW sensor FFC
- Remove the screws (x4) for securing "Board, Main" with the order in figure, and remove "Board, Main".

- Remove "Shield Plate, M/B" from "Board, M/B".



□ When reinstalling "Board, Main",

- Make sure that all cables/FFCs are correctly connected to the appropriate connector of "Board, Main".
- Make sure to secure the screws in the order as shown in the figure.



□ When having replaced "Main Board", implement the adjustment in the following order. (Refer to Chapter 3 "ADJUSTMENT")

- When possible to read data from the old board
 - EEPROM data copy
- When impossible to read from the old board
 - Replace "Waste Ink Pads" with new one. (To count the amount of the waste ink)
 - Market Setting
 - USB ID Input
 - Waste Ink Pad Counter
 - Head ID Input
 - First Dot Adjustment
 - PW Sensor Adjustment
 - Head Angular Adjustment
 - Bi-D Adjustment
 - Offset Input for CR Motor Calorific Limitation

2.3.8 Holder, Shaft Unit removal

□ External View

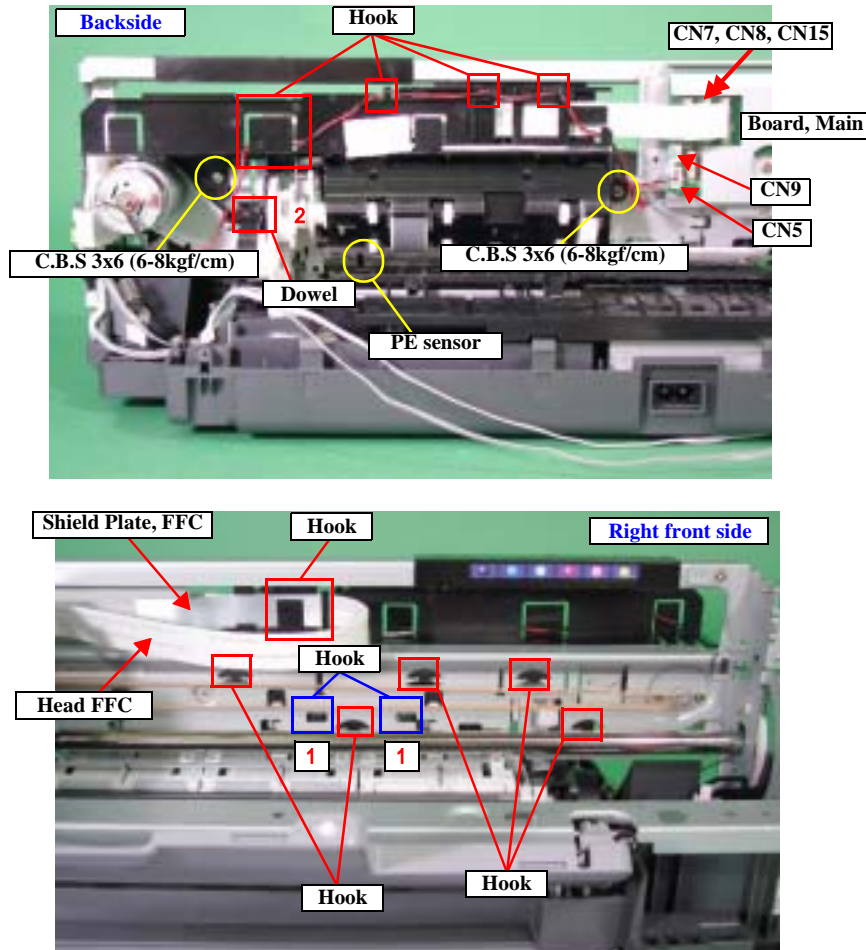

Figure 2-13. "Holder, Shaft Unit" removal (1)

- Parts/Units which should be removed before removing "Holder, Shaft Unit"
Paper Support Assy./Housing (left/right)/Housing (frame)/ASF Assy.

□ Disassembly Procedure

■ Holder, Shaft Unit removal

1. Release the following connector cables from "Board, Main".
 CN5 : CR motor connector cable
 CN7 : Head FFC
 CN8 : Head FFC
 CN9 : PE sensor connector cable
 CN15 : CSIC/CR encoder/PW sensor FFC
2. Release the CR motor connector cable from "Holder, Shaft Unit".
3. Move "Carriage Unit" to the left side of the printer.
4. Remove the screws (x2) for securing "Holder, Shaft Unit".
5. Release the Head FFC with "Shield Plate, FFC" from "Holder, Shaft Unit".



- Do not use "Shield Plate, FFC" again if you peel it off.
- Do not damage "Shield Plate, FFC".
- Do not damage "Cable, Head".

6. Release the hooks (1: x2) with the tweezers or alike while pulling "Holder, Shaft Unit" upward, and release the dowel (2: x1) from "Ink System Frame".
7. Looking at the printer from its back side, press down "Paper Guide, Upper" on the left, and release "PE Sensor Lever" from the slot. Then, remove "Holder, Shaft Assy." by sliding it to the right.



Be careful not to damage "PE Sensor Lever" and "Paper Guide, Upper" when removing them since "PE Sensor Lever" contacts with "Paper Guide, Upper".

External View

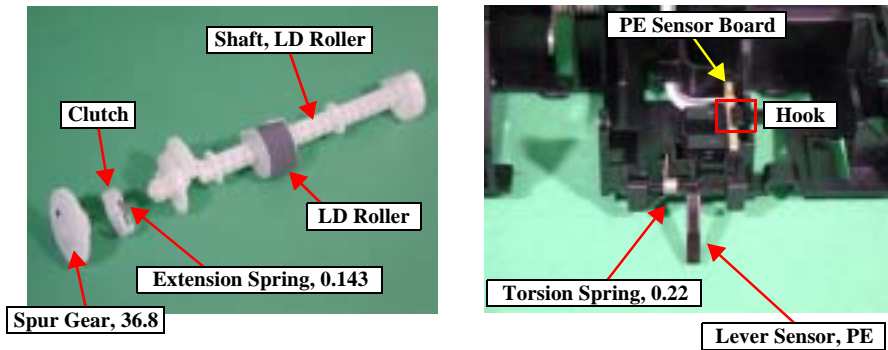
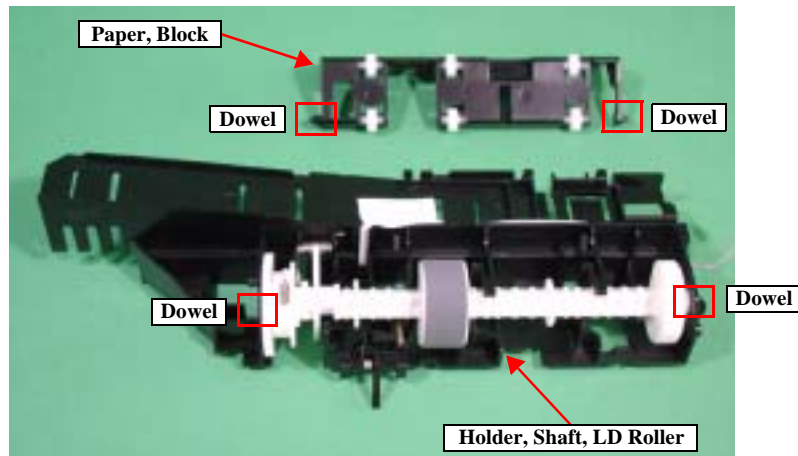

Figure 2-14. "Holder, Shaft Assy." removal (2)

"LD Roller" removal

1. Release the dowels (x2) for securing "Paper, Block".
2. Release the dowels (x2) for securing "Shaft, LD Roller". Then, remove "Shaft, LD Roller" and "Clutch" together from "Holder, Shaft, LD Roller".
3. Remove "LD Roller" from "Shaft, LD Roller".



Do not touch "LD Roller" with bare hands.



- When reinstalling "LD Roller",
 - Make sure to match the direction (△ Mark) indicated on "Shaft, LD Roller" and the direction (△ Mark) indicated on the back side of "LD Roller".

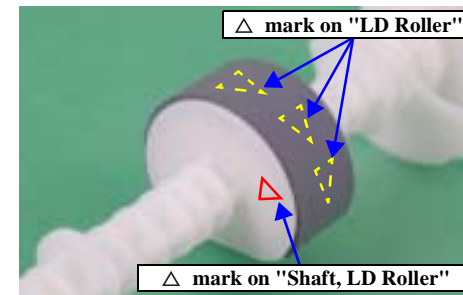

Figure 2-15. Position of "Torsion Spring, 137.7"



- When reinstalling "Clutch",
 - Make sure that the dowel of "Shaft, LD Roller" is fitted in the installing hole of "Clutch".
 - Make sure that "Extension Spring, 0.143" is securely set on the hooks of "Clutch" and "Shaft, LD Roller".
 - Do not set "Extension Spring, 0.143" in twisted form.
 - Make sure that "Clutch" rotates correctly.
- When reinstalling "Shaft, LD Roller",
 - Do not touch "LD Roller".
 - Check if the straight part of "Torsion Spring, 137.7" is set between the 2 cams of "Shaft, LD Roller".

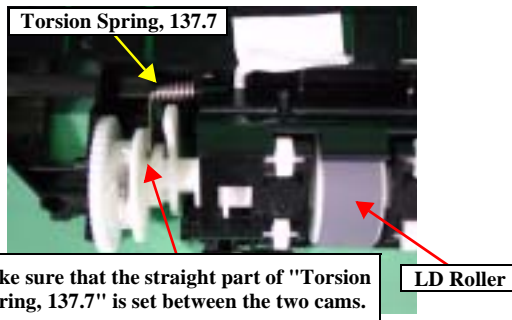

Figure 2-16. Position of "Torsion Spring, 137.7"



- When reinstalling "Holder, Shaft Unit",
 - Check if the hooks (x2), the dowel and the ribs (x5) of "Holder, Shaft Assy." are correctly secured.
 - Check if the connector cable of "PE Sensor" and "Cable, Head" are installed at the correct position of "Holder, Shaft Assy.".
 - Do not touch "LD Roller".
 - Do not damage the teeth of "Spur Gear, 36.8" and "Combination Gear, 27.2, 19.2".

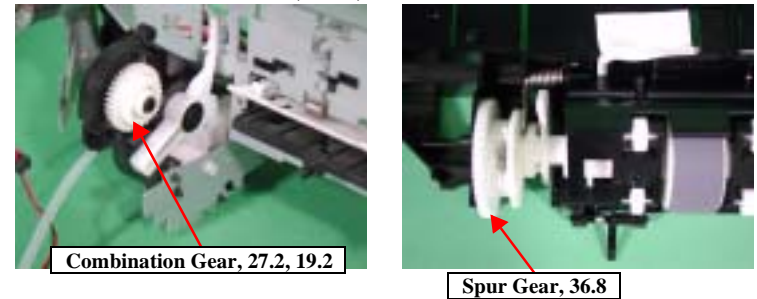

Figure 2-17. "Spur Gear, 36.8" and "Combination Gear, 27.2, 19.2"



- When having replaced "Shaft, LD Roller", apply G-46 grease to the specified points in adequate dose. (Refer to Chapter 4 "MAINTENANCE")
- When having replaced or removed "Holder, Shaft Unit", implement the following adjustment. (Refer to Chapter 3 "ADJUSTMENT")
 - First Dot Adjustment

2.3.9 APG Unit removal

□ External View

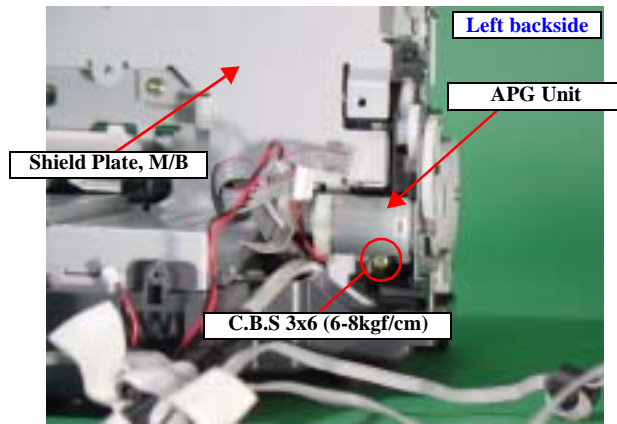

Figure 2-18. "APG Unit" removal

□ Parts/Units which should be removed before removing "APG Unit"

Paper Support Assy./Housing (left/right)/Housing (frame)/ASF Unit/Board, Main

□ Disassembly Procedure

1. Disconnect the APG motor connector cable from the connector (CN13) of "Main Board".
2. Remove the screw (x1) for securing "APG Unit", and remove the "APG Unit" carefully.



- When reassembling "APG Unit",
 - Make sure that the hooks (x2) and the dowels (x2) of "APG Unit" are securely attached to "Frame, Main".
 - Check if the part indicated in the following figure is inserted in the slits of "Frame, Main".

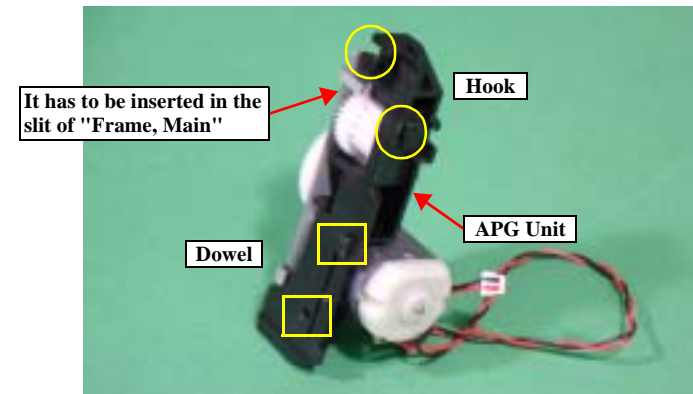

Figure 2-19. "APG Unit" installation

2.3.10 Paper Guide, Upper removal

□ External View

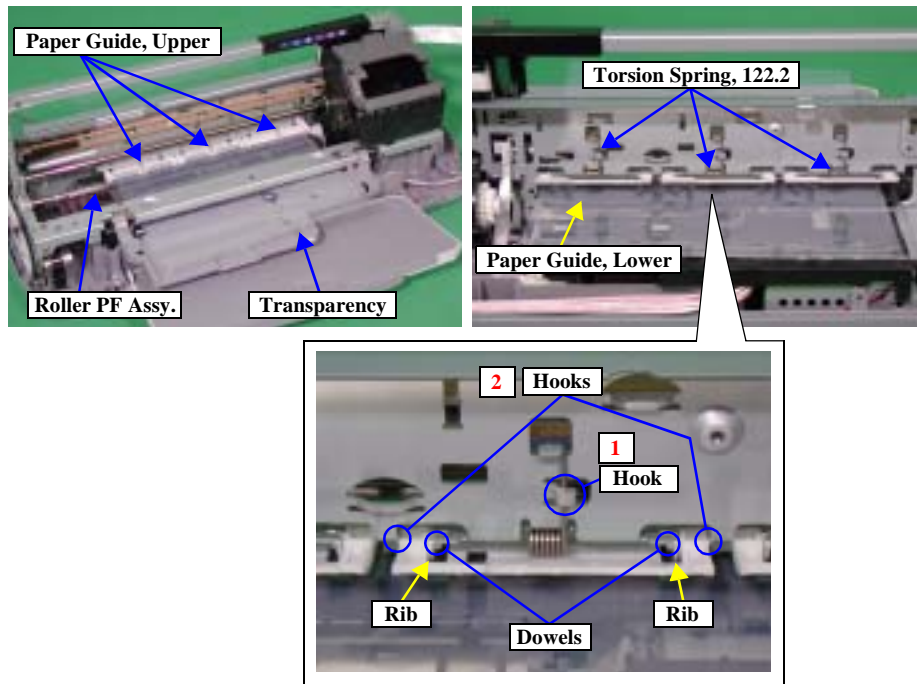

Figure 2-20. "Paper Guide, Upper" removal

□ Parts/Units which should be removed before removing "Paper Guide, Upper"

Paper Support Assy./Housing (left/right)/Housing (frame)/ASF Unit/Board, Main/Holder, Shaft Unit

□ Disassembly Procedure

1. Move "Carriage Unit" to the home position.
2. Put a transparency between "Paper Guide, Upper" and "Roller PF Unit".
3. Release "Torsion Spring, 122.2" (x3) from the hook (1: 1 each) of "Frame, Main", then pull it out to the front.
4. Release the hooks (2: 2 each) for securing "Paper Guide, Upper" (x3) to upward. Then, release the dowels (2 each) while slightly holding up "Paper Guide, Upper".
5. Press down "Paper Guide, Lower" and pull out "Paper Guide, Upper" (x3) to the front while stepping it aside the ribs (2 each) of "Frame, Main"



□ When reinstalling "Paper Guide, Upper",

- There are 2 types of "Driven Rollers" of "Paper Guide, Upper". Install them as shown in the following figure.

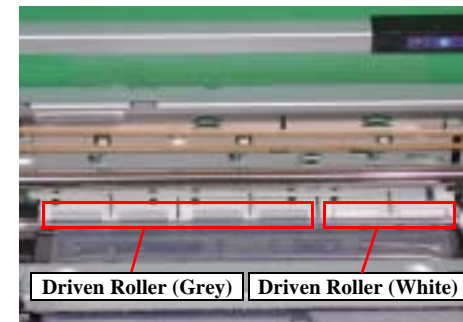

Figure 2-21. Installation Position of "Paper Guide, Upper"